

“Design of Genetically Tuned Interval Type-2 Fuzzy PID controller for Load Frequency Control (LFC) in the Un-regulated Power System”

¹Anita Singh, ²Manoj Jha, ³M.F. Qureshi

^{1,2}Department of Applied Mathematics, Rungta Engg. College, Raipur, India.

³Department of Electrical Engg., Govt. Polytechnic, Narayanpur, India.

Abstract

This paper presents an Genetically Tuned interval type-2 fuzzy PID controller (GT-IT2FPIDC) for the solution Load Frequency Control (LFC) problem in a deregulated power system that operate under deregulation based on the bilateral policy scheme. The interval type-2 fuzzy PID controller (GT-IT2FPIDC) is expected to compensate for the sudden load change, as the most effective countermeasure. In order to overcome difficulty of accuracy constructing the rule base in the IT2FPIDC, the parameters of the proposed controller is tuned by Genetic Algorithm (GA). The aim is to reduce interval type-2 fuzzy system effort, find a better fuzzy system control and take large parametric uncertainties into account. The proposed GA based IT2FPIDC controller is tested on a three-area deregulated power system. Analysis reveals that the proposed control strategy improves significantly the dynamical performances of system such as settling time and overshoot against parametric uncertainties for a wide range of area load demands and disturbances in either of the areas even in the presence of system nonlinearities. This newly developed strategy leads to a flexible controller with a simple structure that is easy to implement and therefore it can be useful for the real world power system. The proposed method is tested on a three-area power system with different contracted scenarios under various operating conditions. The results of the proposed controller are compared with the classical fuzzy PID type controller (CFPIDC).

Keywords:

LFC, Interval Type-2 Fuzzy PID Controller, Classical Fuzzy PID Controller Deregulated, GA Tuning.

1. Introduction

Global analysis of the power system markets shows that the frequency control is one of the most profitable ancillary services at these systems. This service is related to the short-term balance of energy and frequency of the power systems. The most common methods used to accomplish frequency control are generator governor response (primary frequency regulation) and Load

Frequency Control (LFC). The goal of LFC is to re-establish primary frequency regulation capacity, return the frequency to its nominal value and minimize unscheduled tie-line power flows between neighboring control areas. From the mechanisms used to manage the provision this service in ancillary markets, the bilateral contracts or competitive offers stand out.

The dynamic behaviour of many industrial plants is heavily influenced by disturbances and, in particular, by changes in the operating point. This is typically the case for the restructured power systems. Load Frequency Control (LFC) is a very important issue in power system operation and control for supplying sufficient and reliable electric power with good quality. The main goal of the LFC is to maintain zero steady state errors for frequency deviation and good tracking load demands in a multi-area restructured power system. In addition, the power system should fulfil the requested dispatch conditions. A lot of studies have been made in the last two decades about the LFC in interconnected power systems. The real world power system contains different kinds of uncertainties due to load variations, system modelling errors and change of the power system structure. As a result, a fixed controller based on the classical theories is certainly not suitable for the LFC problem. Consequently, it is required that a flexible controller be developed. The conventional control strategy for the LFC problem is to take the integral of the area control error as the control signal. An integral controller provides zero steady state deviation but it exhibits poor dynamic performance. To improve the transient response, various control strategy, such as linear feedback, optimal control and variable structure control have been proposed. However, these methods need some information for the system states, which are very difficult to know completely. There have been continuing efforts in designing LFC with better performance to cope with the plant parameter changes, using various adaptive neural networks and robust methods. The proposed methods show good dynamical responses, but robustness in the presence of model dynamical uncertainties and system nonlinearities were not considered. Also, some of them suggest complex state feedback or high order dynamical controllers, which are not practical for industry practices.

Recently, some authors proposed fuzzy PID methods to improve performance of the LFC problem. It should be pointed out that they require a three dimensional rule base. This problem makes the design process is more difficult. To overcome this drawback, an improved control strategy based on fuzzy theory and Genetic Algorithm (GA) technique has been proposed. In order for a fuzzy rule based control system to perform well, the fuzzy sets must be carefully designed.

Research on the LFC problem shows that, the fuzzy Proportional-Integral (PI) controller is simpler and more applicable to remove the steady state error. The fuzzy PI controller is known to give poor performance in the system transient response. In view of this, some authors proposed fuzzy Proportional-Integral-Derivative (PID) methods to improve the performance of the fuzzy PI controller. In order to overcome this drawback and focus on the separation PD part from the integral

part, this paper presents an Interval Type-2 Fuzzy PID (IT2FPID) controller with GA tuning. This is a form of behaviour based control where the PD controller becomes active when certain conditions are met. The resulting structure is a controller using two- dimensional inference engines (rule base) to reasonably perform the task of a three-dimensional controller. The proposed method requires fewer resources to operate and its role in the system response is more apparent, i.e. it is easier to understand the effect of a two-dimensional controller than a three-dimensional one. This newly developed control strategy combines interval type-2 fuzzy PD controller and GA tuning. The fuzzy PD stage is employed to penalize fast change and large overshoots in the control input due to corresponding practical constraints.

The proposed control has simple structure and does not require an accurate model of the plant. Thus, its construction and implementation are fairly easy and can be useful for the real world complex power system. The proposed method is applied to a three-area restructured power system as a test system. The results of the proposed IT2FPID controller are compared with the Classical Fuzzy PID controller (CFPIDC) in the presence of large parametric uncertainties and system nonlinearities under various area load changes. The performance indices have been chosen as the Integral of the Time multiplied Absolute value of the Error (ITAE), the Integral of the Time multiplied Square of the Error (ITSE), Integral of the Square of the Error (ISE) and Fig. of Demerit (FD). The simulation results show that not only the proposed controller can guarantee the robust performance for a wide range of load changes and parametric uncertainties even in the presence of Generation Rate Constraints (GRC), but also the system performance such as: ITAE, ITSE, ISE and FD indices are very better than the CFPID.

Assuming that parametric models are available, in this case, using soft computing methods would be helpful in order to adjust model parameters over full range of input–output operational data. Genetic Algorithms (GA) have outstanding advantages over the conventional optimization methods, which allow them to seek globally for the optimal solution. It causes that a complete system model is not required and it will be possible to find parameters of the model with nonlinearities and complicated structures. In the recent years, Genetic Algorithms are investigated as potential solutions to obtain good estimation of the model parameters and are widely used as an optimization method for training and adaptation approaches. In this paper, interval type-2 fuzzy PID controller (IT2PIDC) model is first developed for Load frequency control then, the related parameters are adjusted by applying Genetic Algorithms.

2. Genetically Tuned Interval Type-2 Fuzzy PID controller

The most popular technique in evolutionary computation research has been the Genetic Algorithm which can be applied to any problem that can be formulated as function optimization

problem [Sivanandam and Deepa (2008)]. By tuning the gains of the Interval Type-2 Fuzzy PID Controller model using Genetic Algorithm better results are obtained [Sufian and Surendra (2008b)]. Interval Type-2 Fuzzy PID Controller model can be tuned by various methods, like changing the scaling factor, modifying the support and spread of membership functions, modifying the rules of the Rule base and changing the type of a membership function itself, doing so will result in change of the control surface and hence the output of the Interval Type-2 Fuzzy PID Controller model [Drainkov et al (1993)]. The usefulness of Rule tuning is demonstrated by *F. Herrera et al* [Herrera et al (1995)]. Membership function tuning using Genetic Algorithm is studied by *Rafael Alcala et al* [Rafael et al (2005)], where it was seen how the performance would be improved by tuning the lateral position and support of the membership function. In addition to these the rule weights can also be changed to perform a local tuning of linguistic rules, which enables the linguistic fuzzy models to cope with inefficient and/or redundant rules thereby enhancing the robustness, flexibility and system modeling capability [Rafael et al (2003a)]. By assigning a rule weight to each of the fuzzy rules, complexity is increased while its accuracy is improved which suggests a trade-off relation between the accuracy and complexity [Hisao et al (2009)]. If a rule weight is applied to the consequent part of the rule, it modifies the size of the rule's output value [Nauck (2000)]. Parameters like rules, membership functions and rule-weights play an important role in any fuzzy model, and optimizing them is a necessary task, since these parameters are always built by designers with trial and error along with their experience or experiments. After performing the tuning of individual parameters, an inference is drawn as to which procedure is better than the other with reference to ISE criterion.

Genetic Algorithm-based parameter

Learning GAs is optimization technique for the natural selection, which consists of three operations, namely, reproduction, crossover, and mutation [Fleming et al (2002)]. The most general considerations about GA can be stated as follows:

1. The searching procedure of the GA starts from multiple initial states simultaneously and proceeds in all of the parameter subspaces simultaneously.
2. GA requires almost no prior knowledge of the concerned system, which enables it to deal with the completely unknown systems that other optimization methods may fail.
3. GA cannot evaluate the performance of a system properly at one step. For this reason, it can generally not be used as an on-line optimization strategy and is more suitable for fuzzy modeling.

Genetic Fuzzy Systems

The genetic fuzzy systems are primarily used to automate the knowledge acquisition step in fuzzy system design, a task that is usually accomplished through an interview or observation of a human expert controlling the system [Hoffmann (2001)]. An evolutionary algorithm adapts either part or all of the components of the fuzzy knowledge base. Fuzzy knowledge base is not a monolithic structure but is composed of the data base and the rule base where each plays a specific role in the fuzzy reasoning process. Genetic tuning processes are targeted at optimizing the performance of an already existing fuzzy system. Designing a fuzzy rule based system is equivalent to finding the optimal configuration of fuzzy sets and/or rules, and in that sense can be regarded as an optimization problem. The optimization criterion is the problem to be solved at hand and the search space is the set of parameters that code the membership functions, fuzzy rules and fuzzy rule-weights. The Fig.1 represents a genetic fuzzy system. The performance is aggregated into a scalar fitness value on which basis the evolutionary (Genetic) algorithm selects better adapted chromosomes. A chromosome either codes parameters of membership functions, fuzzy rules and fuzzy rule-weights or a combination thereof. By means of crossover and mutation, the evolutionary algorithm generates new parameters for the database and/or rule base whose usefulness is tested in the fuzzy system.

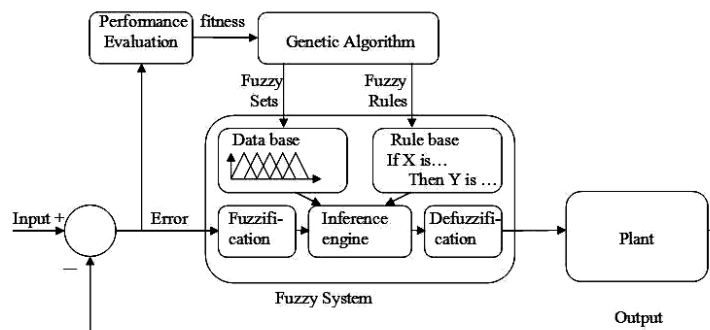

Fig.1. Genetic Fuzzy System

The objective functions considered here is based on the error criterion. In this paper performance of membership functions, rules and weight tuning are evaluated in terms of Integral square Error (ISE) error criteria. The error criterion is given as a measure of performance index. The ISEs of individual parameters are added together to obtain an overall ISE. This is done to simplify the task of Genetic Algorithm. The objective of Genetic Algorithm is to minimize this overall ISE. The overall ISE is given by Equation 6.

$$ISE = \sum_{i=1}^6 \int e_i^2(t) dt \tag{6}$$

Where $e_i(t)$ is the error signal for the i^{th} parameter. Here i can take values from 1 to 6 corresponding to 6 parameters.

Interval Type-2 Fuzzy Logic Systems (IT2FLS)

In recent years, fuzzy logic has emerged as a powerful tool and is starting to be used in various power system applications. Fuzzy logic can be an alternative to classical control. It allows one to design a controller using linguistic rules without knowing the mathematical model of the plant. This makes fuzzy-logic controller very attractive systems with uncertain parameters. The linguistic rule necessary for designing a fuzzy-logic controller may be obtained directly from the operator who has enough knowledge of the response of the system under various operating conditions. The inference mechanism of the fuzzy-logic controller is represented by a decision table, which consists of linguistic IF-THEN rule. It is assumed that an exact model of the plant is not available and it is difficult to extract the exact parameters of the power plant. Therefore, the design procedure cannot be based on an exact model. However the fuzzy logic approach makes the design of a controller possible, without knowing the mathematical (exact) model of the plant.

Interval Type-2 fuzzy sets, characterized by membership grades that are themselves fuzzy, were introduced by Zadeh in 1975 to better handle uncertainties. As illustrated in Fig.2, the membership function (MF) of a type-2 set has a footprint of uncertainty (FOU), which represents the uncertainties in the shape and position of the type-1 fuzzy set. The FOU is bounded by an upper MF and a lower MF, both of which are type-1 MFs. Fuzzy logic systems constructed using rule bases that utilize at least one interval type-2 fuzzy sets are called interval type-2 FLSs. Since the FOU of a type-2 fuzzy set provides an extra mathematical dimension, type-2 FLSs can better handle system uncertainties and have the potential to outperform their type-1 counterparts.

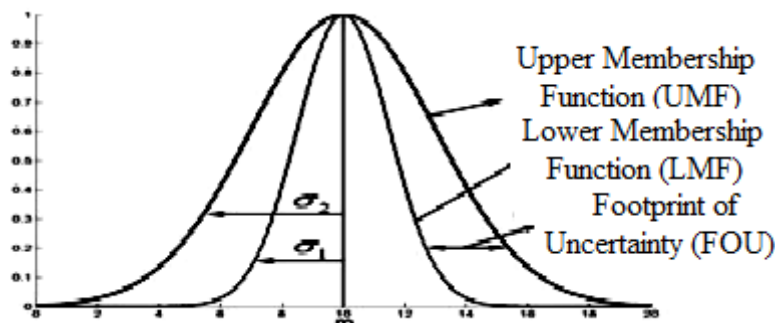

Fig.2. Interval type-2 fuzzy sets

Fuzzy Logic Systems (FLS) are known as the universal-approximators and have various applications in identification and control designs. A type-1 fuzzy system consists of four major parts: fuzzifier, rule base, inference engine and defuzzifier. A type-2 fuzzy system has a similar structure, but one of the major differences can be seen in the rule base part, where a type-2 rule base

has antecedents and consequents using Type-2 Fuzzy Sets (T2FS). In a T2FS, we consider a Gaussian function with a known standard deviation, while the mean (m) varies between m_1 and m_2 . Because of using such a uniform weighting, we name the T2FS as an Interval Type-2 Fuzzy Set (IT2FS). Utilizing a rule base which consists of IT2FSs, the output of the inference engine will also be a T2FS and hence we need a type-reducer to convert it to a type-1 fuzzy set before defuzzification can be carried out. Fig.3 shows the main structure of type-2 FLS. By using singleton fuzzification, the singleton inputs are fed into the inference engine. Combining the fuzzy if-then rules, the inference engine maps the singleton input $x = [x_1, x_2, \dots, x_n]$ into a type-2 fuzzy set as the output. A typical form of an if-then rule can be written as:

$$R_i = \text{if } x_1 \text{ is } \tilde{F}_1^i \text{ and } x_2 \text{ is } \tilde{F}_2^i \text{ and } \dots \text{ and } x_n \text{ is } \tilde{F}_n^i \text{ then } \tilde{G}^i \quad (1)$$

where F_k^s are the antecedents ($k = 1, 2, \dots, n$) and G^i is the consequent of the i th rule. We use sup-star method as one of the various inference methods. The first step is to evaluate the firing set for i th rule as following:

$$F^i(\underline{x}) = \prod_{i=1}^n \mu_{\tilde{F}_i}(x_1) \quad (2)$$

As all of the F_k^s are IT2FSs, so $F^i(\underline{x})$ can be written as $F^i(\underline{x}) = [f^i(\underline{x}), \bar{f}^i(\underline{x})]$ where:

$$\underline{f}^i(\underline{x}) = \prod_{i=1}^n \underline{\mu}_{\tilde{F}_i}(x_1) \quad (3)$$

$$\bar{f}^i(\underline{x}) = \prod_{i=1}^n \bar{\mu}_{\tilde{F}_i}(x_1) \quad (4)$$

The terms $\underline{\mu}_{F_1}$ and $\bar{\mu}_{F_1}$ are the lower and upper membership functions, respectively (Fig.1). In the next step, the firing set $F_i(x)$ is combined with the i^{th} consequent using the product t-norm to produce the type-2 output fuzzy set. The type-2 output fuzzy sets are then fed into the type reduction part. The structure of type reducing part is combined with the defuzzification procedure, which uses Center of Sets (COS) method. First, the left and right centroids of each rule consequent are computed using Karnik-Mendel (KM) algorithm. Let's call them y_l and y_r respectively. The firing sets $F^i(\underline{x}) = [f^i(\underline{x}), \bar{f}^i(\underline{x})]$ computed in the inference engine are combined with the left and right centroid of consequents and then the defuzzified output is evaluated by finding the solutions of following optimization problems:

$$y_l(\underline{x}) = \min_{\forall f^k \in \{\underline{f}^k, \bar{f}^k\}} (\sum_{i=1}^M y_l^i f^i(\underline{x}) / \sum_{i=1}^M f^i(\underline{x})) \quad (5)$$

$$y_r(\underline{x}) = \max_{\forall f^k \in \{\underline{f}^k, \bar{f}^k\}} (\sum_{i=1}^M y_r^i f^i(\underline{x}) / \sum_{i=1}^M f^i(\underline{x})) \quad (6)$$

Define $f_l^k(\underline{x})$ and $f_r^k(\underline{x})$ as a functions which are used to solve (5) and (6) respectively and

let $\xi_1^i(\underline{x}) = f_l^i(\underline{x}) / \sum_{i=1}^M f_l^i(\underline{x})$

And $\xi_r^i(\underline{x}) = f_r^i(\underline{x}) / \sum_{i=1}^M f_r^i(\underline{x})$

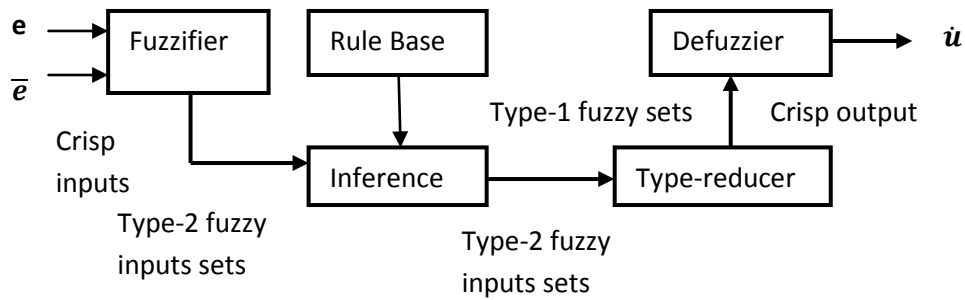

Fig.3: Main structure of interval type-2 FLS

Then we can write (5) and (6) as:

$$y_l(\underline{x}) = \frac{\sum_{i=1}^M y_l^i f_l^i(\underline{x})}{\sum_{i=1}^M f_l^i(\underline{x})} = \sum_{i=1}^M y_l^i \xi_l^i(\underline{x}) = \theta_l^T \xi_l(\underline{x}) \quad (7)$$

$$y_r(\underline{x}) = \frac{\sum_{i=1}^M y_r^i f_r^i(\underline{x})}{\sum_{i=1}^M f_r^i(\underline{x})} = \sum_{i=1}^M y_r^i \xi_r^i(\underline{x}) = \theta_r^T \xi_r(\underline{x}) \quad (8)$$

Where

$$\xi_l(\underline{x}) = [\xi_l^1(\underline{x}) \ \xi_l^2(\underline{x}) \ \dots \ \xi_l^M(\underline{x})]$$

And $\xi_r(\underline{x}) = [\xi_r^1(\underline{x}) \ \xi_r^2(\underline{x}) \ \dots \ \xi_r^M(\underline{x})]$ are the fuzzy basis functions and

$$\theta_l(\underline{x}) = [y_l^1(\underline{x}) \ y_l^2(\underline{x}) \ \dots \ y_l^M(\underline{x})]$$

And $\theta_r(\underline{x}) = [y_r^1(\underline{x}) \ y_r^2(\underline{x}) \ \dots \ y_r^M(\underline{x})]$ are the adjustable parameters.

Finally, the crisp value is obtained by the defuzzification procedure as follows:

$$y(\underline{x}) = \frac{1}{2} [y_l(\underline{x}) + y_r(\underline{x})] = \frac{1}{2} [\theta_l^T \xi_l(\underline{x}) + \theta_r^T \xi_r(\underline{x})] = \frac{1}{2} \theta^T \xi(\underline{x}) \quad (9)$$

Where

$$\theta = [\theta_l^T \ \theta_r^T]^T \quad \text{and} \quad \xi = [\xi_l^T \ \xi_r^T]^T$$

1. A typical LFC is constructed as a set of heuristic control rules, and the control signal is directly deduced from the knowledge base.
2. The gains of the conventional PID controller are tuned on-line in terms of the knowledge based and fuzzy inference, and then, the conventional PID controller generates the control signal.

The structure of the classical FPID controller is shown in Fig.4. which in the PID controller gains is tuned online for each of the control areas. Fig.5 a, b & c show membership for ACE, membership for ΔACE and membership for K_{i_i} , K_{P_i} and K_{d_i} respectively.

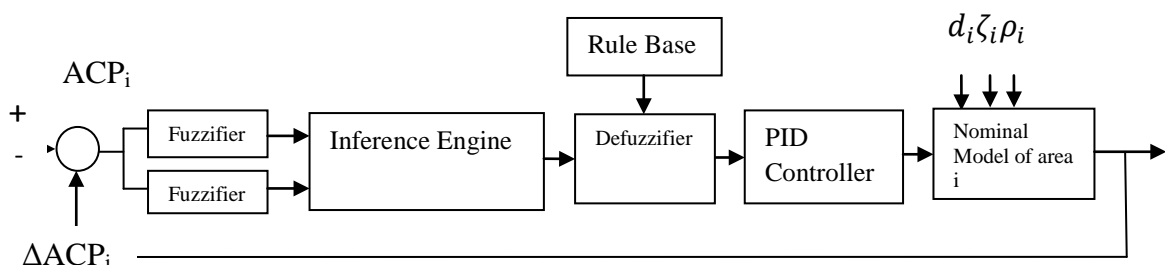

Fig.4 Classical Fuzzy PID Controller (CFPIDC)

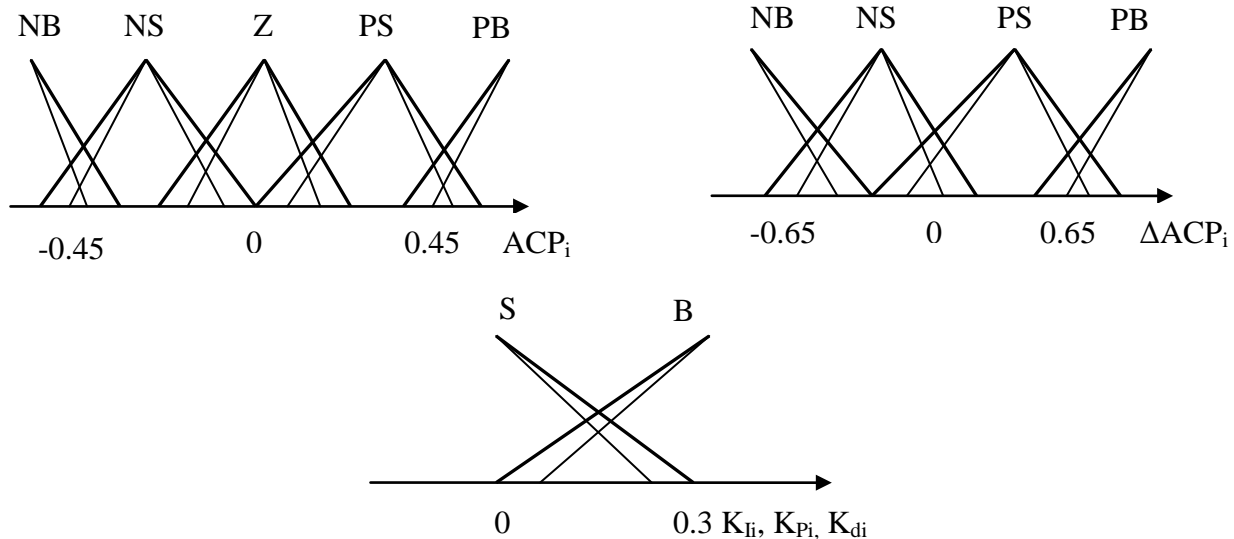

Fig.5. a) Membership for ACE b) Membership for ΔACE c) Membership for K_{ii} , K_{Pi} and K_{di}

In the design of fuzzy logic controller, there are five parts of the fuzzy inference process:

1. Fuzzification of the input variables.
2. Application of the fuzzy operator (AND or OR) in the antecedent.
3. Implication from the antecedent to the consequent.
4. Aggregation of the consequents across the rules.
5. Defuzzification.

According to the control methodology a interval type-2 fuzzy PID controller (IT2FPIDC) for each of three areas is designed. The proposed controller is a two-level controller. The first level is fuzzy network and the second level is PID controller. The structure of the classical FPID controller is shown in Fig. 4, where the PID controller gains are tuned online for each of the control areas. The controller block is formed by fuzzification of Area Control Error (ACE), the interface mechanism and defuzzification. Therefore U_i is a control signal that applies to governor set point in each area. By taking ACE_i as the system output, the control vector for a conventional PID controller is given by:

$$u_i = K_{Pi} ACE_i(t) + K_{Ii} \int_0^t ACE_i(t) dt + K_{di} \dot{ACE}_i(t)$$

In this strategy, the conventional controller for LFC scheme is replaced by Interval Type-2 fuzzy PID type controller (IT2FPIDC). The gains K_{Pi} , K_{Ii} and K_{di} are tuned on-line in terms of the knowledge base and fuzzy inference, and then, the conventional PID controller generates the control signal. The motivation of using the fuzzy logic for tuning gains of PID controllers is to take

large parametric uncertainties, system nonlinearities and to minimize the area load disturbances. Fuzzy logic shows experience and preference through its membership functions. These functions have different shapes depending on the system expert's experience. The membership function sets for ACE, ΔACE_i , K_{Ii} , K_{di} and K_{pi} , are shown in Fig.5. The appropriate rules for the proposed control strategy are given in Tables 1, 2 and 3.

This control methodology for the LFC problem shows good dynamical responses with robustness in the presence of dynamical uncertainties and system nonlinearities. From Fig.4, It should be pointed out that fuzzy PID controller normally requires a three-dimensional rule base. This is difficult to obtain since three-dimensional information is usually beyond the sensing capability of a human expert and it makes the design process more complex.

4. LFC Scheme in Deregulated Power System

In the deregulated power systems, the vertically integrated utility no longer exists. However, the common LFC objectives, i.e. restoring the frequency and the net interchanges to their desired values for each control area, still remain. The deregulated power system consists of Generator Groups (GGs), Transformer Groups (TGs) and Distribution Groups (DGs) with an open access policy. In the new structure, GGs may or may not participate in the LFC task and DGs have the liberty to contract with any available GGs in their own or other areas. Thus various combinations of possible contracted cases between DGs and GGs are possible. All the Transactions have to be cleared by the Independent System Operator (ISO) or other responsible organizations. In this new environment, it is desirable that a new model for LFC scheme be developed to account for the effects of possible load following contracts on system dynamics. Fig.5 shows the block diagram of fuzzy type controller to solve the LFC problem for each control area.

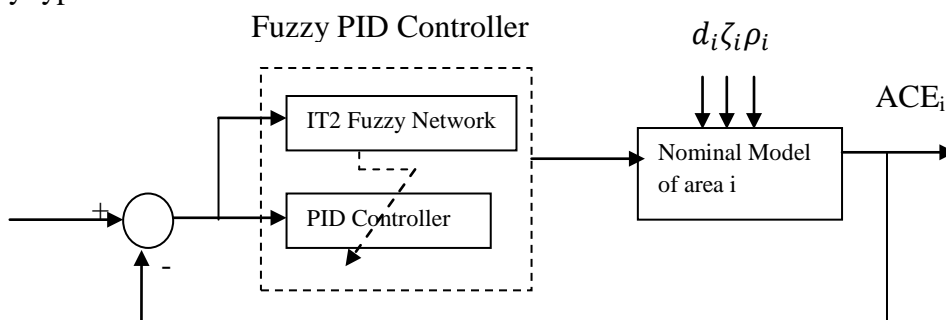

Fig.6 The proposed FPID controller design

Based on the idea presented, the concept of an ‘*Augmented Generation Participation Matrix*’ (AGPM) to express the possible contracts following is presented here. The AGPM shows the participation factor of a GG in the load following contract with a DG. The rows and columns of AGPM matrix equal the total number of GGs and DGs in the overall power system, respectively.

Consider the number of GGs and DGs in area i be n_i and m_i in a large scale power system with N control areas. The structure of AGPM is given by:

$$AGPM = \begin{pmatrix} AGPM_{11} \dots AGPM_{1N} \\ \vdots \\ AGPM_{N1} \dots AGPM_{NN} \end{pmatrix}$$

$$AGPM_{ij} = \begin{pmatrix} gpf_{(Si+1)(zj+1)} \dots gpf_{(Si+1)(zj+mj)} \\ \vdots \\ gpf_{(Si+ni)(zj+1)} \dots gpf_{(Si+ni)(zj+mj)} \end{pmatrix}$$

For $i, j=1, \dots, N$,
 $s_i = \sum_{k=1}^{i-1} n_k$, $z_j = \sum_{k=1}^{j-1} m_k$, $s_i = z_j = 0$

In the above, gpf_{ij} refers to ‘generation participation factor’ and shows the participation factor of GG i in total load following requirement of DG j based on the contracted case. Sum of all entries in each column of AGPM is unity. The diagonal sub-matrices of AGPM correspond to local demands and off-diagonal sub matrices correspond to demands of DGs in one area on GGs in another area. As there are many GGs in each area, ACE signal has to be distributed among them due to their ACE participation factor in the LFC task and $\sum_{j=1}^{n_i} \alpha_{ji} = 1$

The four input disturbance channels, d_i , η , ζ and ρ_i are considered for decentralized LFC design. They are defined as bellow:

$$d_i = \Delta P_{Loc i} + \Delta P_{di}, \Delta P_{Loc i} = \sum_{j=1}^{m_i} (\Delta P_{Lj} + \Delta P_{ULj})$$

$$\eta_i = \sum_{j=1, j \neq i}^N n T_{ij} \Delta f_j$$

$$\zeta_i = \Delta P_{tie, i, sch} = \sum_{k=1, k \neq i}^N \Delta P_{tie, ik, sch}$$

$$\Delta P_{tie, i-error} = \Delta P_{tie, i-actual} - \zeta_i$$

$$\rho_i = [\rho_{1i} \dots \rho_{ki} \dots \rho_{ni}]^T$$

$$\rho_{ki} = \sum_{j=1}^N [\sum_{t=1}^{m_j} gpf_{(Si+k)(zj+t)} \Delta P_{Lt-j}]$$

$$\Delta P_{m, k-i} = \rho_{ki} + apf_{ki} \sum_{j=1}^{m_i} \Delta P_{UL-i}$$

$$\Delta P_{m, k-i} = \rho_{ki} + apf_{ki} \Delta P_{di} \quad k=1, 2, \dots, n_i$$

$\Delta P_{m, ki}$ is the desired total power generation of a GG k in area i and must track the demand of the DGs in contract with it in the steady state. A three area power system as shown in Fig.7 is considered as a test system to demonstrate the effectiveness of the proposed control strategy. It is assumed that each control area includes two GGs and DGs. The power system parameters are given in Tables 1-2.

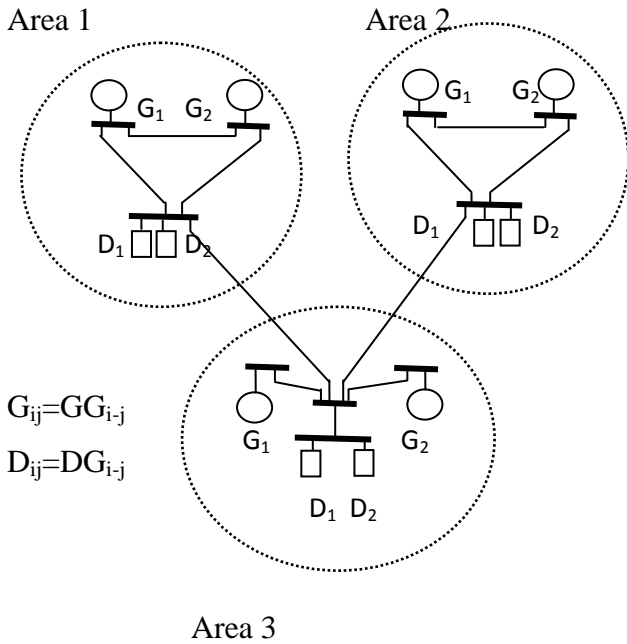

Fig.7 A three-area deregulated power system

Table 1. Control area parameters

Parameter	Area 1	Area 2	Area 3
K_P (Hz/pu)	125	80	100
T_P (sec)	25	15	12
B (pu/Hz)	0.8877	0.85	0.9
T_{ij} (pu/Hz)	$T_{12} = 0.55$	$T_{13} = 0.55$	$T_{23} = 0.55$

Table 2. GGs Parameter

MVA _{base} (1000 MW) Parameter	GGs (k in area i)					
	1-1	2-1	1-2	2-2	1-3	2-3
Rate (MW)	1100	900	1200	1000	1100	1150
T_r (sec)	0.4	0.48	0.46	0.45	0.4	0.45
T_H (sec)	0.08	0.09	0.07	0.09	0.08	0.09
R (Hz/pu)	2.5	3.5	3.0	2.8	2.8	3.5
α	0.45	0.45	0.45	0.45	0.45	0.45

5. Encoding for Fuzzy Rule Base

A major problem plaguing the effective use of this method is the difficulty of accurately constructing the rule bases. Because, it is a computationally expensive combinatorial optimization and also extraction of an appropriate set of rule bases from the expert may be tedious, time consuming and process specific. Thus, to reduce fuzzy system effort cost, a GA has been proposed. It was shown that, the global optimal point is guaranteed and the speed of algorithms convergence is extremely improved, too. GA's are search algorithms based on the mechanism of natural selection and natural genetics. They can be considered as a general-purpose optimization method and have been successfully applied to search and optimization.

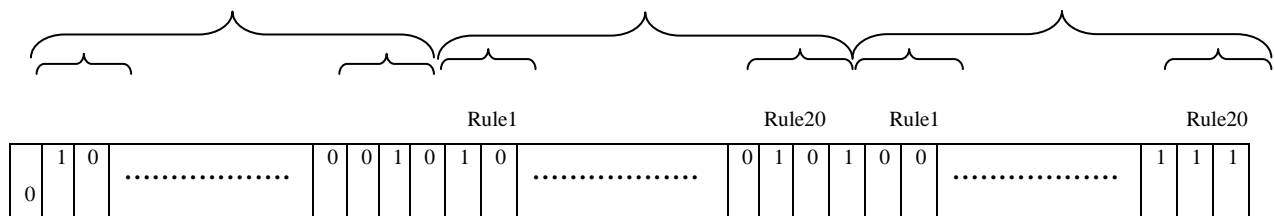

Fig.8 Encoding for fuzzy rule base

In the GA just like natural genetics a chromosomes (a string) will contain some genes. These binary bits are suitably decoded to represent the character of the string. A population size is chosen consisting of several parent strings. The strings are then subjected to evaluation of fitness function. The strings with more fitness function will only survive for the next generation, in the process of the

selection and copying, the string with less fitness function will die. The former strings now produce new off-springs by crossover and some off-springs undergo mutation operation depending upon mutation probability to avoid premature convergence to suboptimal condition. In this way, a new population different from the old one is formed in each genetic iteration cycle. The whole process is repeated for several iteration cycles until the fitness function of an offspring is reach to the maximum value. Thus, that string is the required optimal solution. For our optimization problem, the new following fitness function is proposed:

$$f = \frac{1}{1 + \text{MSE}(\text{performance Index})}$$

$$\text{MSE}(\text{performance Index}) = \sqrt{\left(\sum_{i=1}^3 100 \int_0^t |ACE_i| dt / 3 \right)}$$

A string of 200 binary bits reprints gains of PID controller in three areas (Fig. 8), population size and maximum generation are 30 and 120, respectively. The least MSE is the better string. The better string survives in the next population. Based on the roulette wheel, some strings are selected to make the next population. After the selection and copying the usual mutual crossover of the string (crossover probability is chosen 98%) and mutation of some of the string (mutation probability is chosen 10%) are performed. In this way, new offspring of rule sets are produced in the total population then system performance characteristics and corresponding fitness value are recomputed for each string. Thus, the sequential process of fitness function, selection, crossover, mutation evaluation completes genetic iteration cycle. In the GAs rule base optimization we assume that the fuzzy sets C_i and D_i are characterized by the membership functions shown in Fig.9.

The proposed method was applied to the LFC task in the deregulated power system. The plot of obtained fitness function value is shown in Fig.10. It can be seen that the fitness value increases monotonically from 0.16 to 0.28 in 98 generations. The fuzzy rule base is listed in Tables 3, 4 and 5.

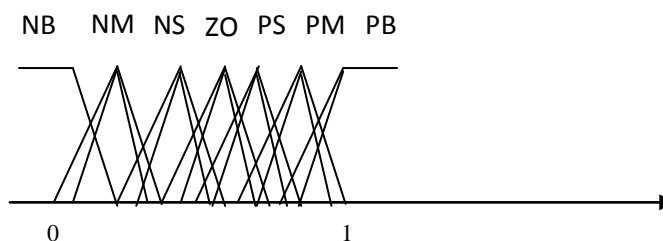

Fig. 9 Membership function for K_{Ii} , K_{Pi} and

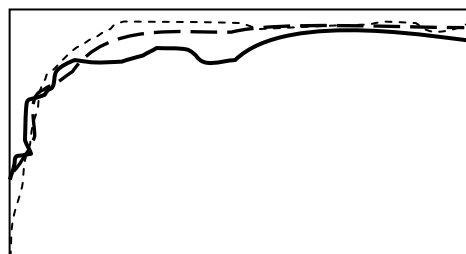

Fig.10 Convergence procedure of GA to obtain fuzzy rule table Solid (Max. value), Dashed (Mean Value) and Dated (Min. value)

Table 3. Rule Table for K_{Ii}

		ΔACE_i			
		NB	NS	PS	PB
ACE_i	NB	NM	NB	NB	NB
	NS	NM	NB	NB	NM
	Z	NB	PB	PB	NM
	PS	PM	PB	PB	PB
	PB	PS	NM	NM	PM

Table 4. Rule Table for K_{Pi}

		ΔACE_i			
		NB	NS	PS	PB
ACE_i	NB	NS	PS	NB	NB
	NS	PB	NM	ZO	NM
	Z	NB	PB	NS	PM
	PS	PB	PM	NB	PB
	PB	NB	NS	NB	NM

Table 5. Rule Table for K_{di}

		ΔACE_i			
		NB	NS	PS	PB
ACE_i	NB	NS	PS	NB	NB
	NS	PB	NM	ZO	NM
	Z	NB	PB	NS	PM
	PS	PB	PM	NB	PB
	PB	NB	NS	NB	NM

6. Simulation Results

In the simulation study, the linear model of turbine $\Delta PV_{ki}/\Delta PT_{ki}$ is replaced by a nonlinear model of Fig.11 (with ± 0.05 limit). This is to take GRC into account, i.e. the practical limit on the rate of the change in the generating power of each GG. The results indicated that GRC would influence the dynamic responses of the system significantly and lead to larger overshoot and longer settling time. Therefore, to illustrate the capability of the proposed strategy in this example, in the view point of uncertainty our focus will be concentrated on variation of these parameters.

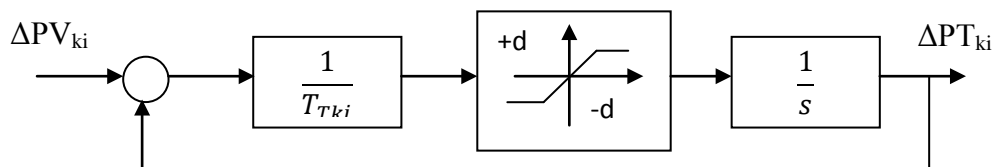

Fig.11 Nonlinear turbine model with GRC

The designed GT-IT2FPIDC controller is applied for each control area of the deregulated power system as shown in Fig. 7. To illustrate robustness of the proposed control strategy against parametric uncertainties and contract variations, simulations are carried out for two Cases of

possible contracts under various operating conditions and large load demands. Performance of the proposed GT-IT2FPIDC controller is compared with CFPIDC controller in power systems.

Case 1: Local Area Control

In this scenario, GGs participate only in the load following control of their areas. It is assumed that a large step load 0.15 pu is demanded by each DGs in areas 1 and 2. Assume that a case 1 of local area contracts between DGs and available GGs are simulated based on the following AGPM. It is noted that GGs of area 3 do not participate in the LFC task.

$$AGPM = \begin{pmatrix} 0.5 & 0.4 & 0 & 0 & 0 & 0 \\ 0.5 & 0.6 & 0 & 0 & 0 & 0 \\ 0 & 0 & 0.6 & 0.6 & 0 & 0 \\ 0 & 0 & 0.6 & 0.6 & 0 & 0 \\ 0 & 0 & 0 & 0 & 0 & 0 \\ 0 & 0 & 0 & 0 & 0 & 0 \end{pmatrix}$$

Also, assume, in addition to the specified contracted load demands 0.15 pu MW, a step load change as a large uncontracted demand is appears in control area 1 and 2, where, DGs of areas 1 and 2 demands 0.1 and 0.06 pu MW of excess power, respectively. This excess power is reflected as a local load of the area and taken up by GGs in the same area. Thus, the total local load in 1 and 2 areas is computed as:

$$\Delta P_{Loc,1} = 0.15 + 0.15 + 0.15 = 0.45 \text{ pu MW}$$

$$\Delta P_{Loc,2} = 0.15 + 0.15 + 0.05 = 0.35 \text{ pu MW}$$

The frequency deviation of two areas and tie-line power flow with 25% increase in all parameters K_{pi}, T_{pi}, B_i and T_{ij} are depicted in Fig. 12. Using GT-IT2FPID controller, the frequency deviation of all areas and the tie-line power are quickly driven back to zero and has small overshoots. Since there are no contracts between areas, the scheduled steady state power flows over tie-line are zero.

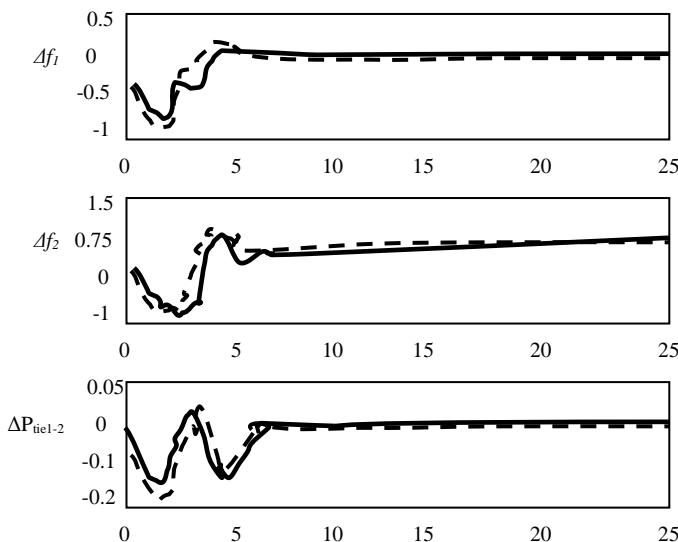

Fig.12 Deviation of frequency and tie-lines power flows using IT2FPIDC controller; Solid (GT-IT2FPIDC) and Dashed (CFPIDC)

Case 2: Global Area Control

In this scenario, DGs have the freedom to have a contract with any GG in their or another areas. Consider that all the DGs contract with the available GGs for power as per following AGPM. All GGs participate in the LFC task. It is assume that a large step load 0.15 pu MW is demanded by each DGs in all areas. Moreover, it is assumed that DGs of areas 1, 2 and 3 demands 0.15, 0.06 and 0.04 pu MW (un-contracted load) of excess power, respectively. The total local load in areas is computed as:

$$\Delta P_{Loc,1} = 0.15 + 0.15 + 0.15 = 0.45 \text{ pu MW}$$

$$\Delta P_{Loc,2} = 0.15 + 0.15 + 0.06 = 0.36 \text{ pu MW}$$

$$\Delta P_{Loc,3} = 0.15 + 0.15 + 0.04 = 0.34 \text{ pu MW}$$

$$AGPM = \begin{pmatrix} 0.3 & 0 & 0.3 & 0 & 0.3 & 0 \\ 0.6 & 0.3 & 0 & 0.3 & 0 & 0 \\ 0 & 0.6 & 0.3 & 0 & 0 & 0 \\ 0.3 & 0 & 0.6 & 0.8 & 0 & 0 \\ 0 & 0.3 & 0 & 0 & 0.6 & 0 \\ 0 & 0 & 0 & 0 & 0 & 1 \end{pmatrix}$$

The purpose of this scenario is to test the effectiveness of the proposed controller against uncertainties and large load disturbances in the presence of GRC. Power systems responses with 25% decrease in uncertain parameters K_{pi} , T_{pi} , B_i and T_{ij} are depicted are shown in Fig.13 and 14. Using the GT-IT2FPID controller, the frequency deviation of the all areas is quickly driven back to zero and has small settling time. Also, the tie-line power flow properly converges to the specified value in the steady state case (Fig.14), i.e.; $\Delta P_{tie12, sch} = 0.03$ and $\Delta P_{tie13, sch} = 0.03$ pu MW. The un-contracted Load of DGs in all areas is taken up by the GGs in these areas according to ACE participation factors in the steady state. The simulation results in the above case indicate that the proposed control strategy can ensure the robust performance such as frequency tracking and disturbance attenuation for possible contracted cases under modelling uncertainties and large area load demands in the presence of GRC.

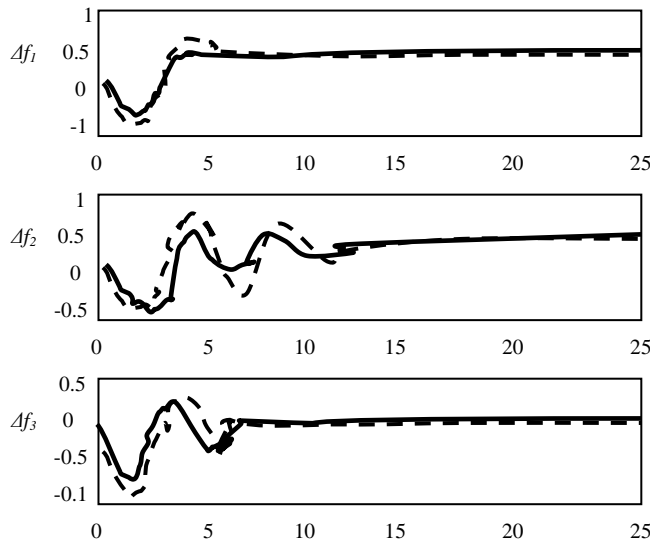

Fig.13 Deviation of frequency using IT2FPIDC controller; Solid (GT-IT2FPIDC) and Dashed (CFPIDC)

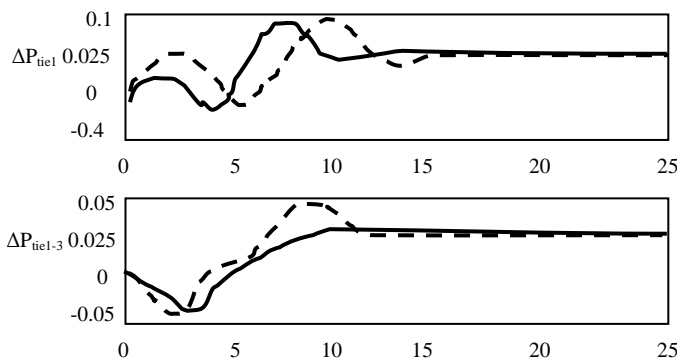

Fig.14 Deviation of tie lines power flows using IT2FPIDC controller; Solid (GT-IT2FPIDC) and Dashed (CFPIDC)

To demonstrate performance robustness of the proposed method, the ISE, ITAE and FD indices based on system performance characteristics are being used as:

$$ISE=1000\int_0^{20} \sum_{i=1}^3 ACE(t)^2 dt$$

$$ITAE=100\int_0^{20} t \sum_{i=1}^3 |ACE(t)| dt$$

$$FD= (OSX14)^2+(USX7)^2+(T_sX1)^2$$

Where, Overshoot (*OS*), Undershoot (*US*) and settling time (*T_s*) (for 5% band of the total load demand in area 1) of frequency deviation area 1 is considered for evaluation of the FD. The value of ISE, ITAE and FD is calculated for cases 1 and 2 whereas the system parameters are varied from -25% to 25% of the nominal values and shown table 6.

Table 6 Performance indices values

Cases	ISE	ITAE	FD
-------	-----	------	----

		GT-IT2FPIDC	CFPIDC	GT-IT2FPIDC	CFPIDC	GT-IT2FPIDC	CFPIDC
1	Experiment 1	24.51	28.76	25.84	121.25	45.33	54.55
	Experiment 2	25.19	26.43	25.08	109.48	45.26	48.93
	Experiment 3	25.74	32.061	29.09	123.96	45.74	107.82
2	Experiment 1	29.47	33.43	26.32	125.78	45.09	117.36
	Experiment 2	29.1	30.23	26.63	115.80	45.23	89.98
	Experiment 3	29.87	37.63	27.59	133.79	45.22	128.87

It can be seen that the GT-IT2FPID controller has robust performance against system parametric uncertainties and possible contract scenarios even in the presence of GRC and the system dynamic performances is significantly improved.

7. Conclusions

In this paper a Genetically tuned interval type-2 fuzzy PID (GT-IT2FPIDC) type controller is proposed for solving the Load Frequency Control (LFC) problem in a deregulated power system that operate under deregulation based on the bilateral policy scheme. This control strategy was chosen because of increasing the complexity and changing structure of power systems. In order to reduce design effort and find better fuzzy system control, a GA with a strong ability to find the most optimistic results algorithm has been used to fuzzy controller rule bases. The aim is to reduce fuzzy system effort, find a better fuzzy system control and take large parametric uncertainties into account. The effectiveness of the proposed method is tested on a three-area deregulated power system for a wide range of load demands and disturbances under different operating conditions. The simulation results show that with the use of GT-IT2FPIDC the dynamic performance of system such as frequency regulation, tracking the load changes and disturbances attenuation is significantly improved for a wide range of plant parameter and area load changes. The system performance characteristics in terms of *ISE*, *ITAE* and *FD* indices reveal that the designed GT-IT2FPID controller is a promising control scheme for the solution of LFC problem and therefore it is recommended to generate good quality and reliable electric energy in the deregulated power systems.

References

1. H. Shayeghi, A. Ghasemi, (March 2011) “Market based LFC Design using Artificial Bee Colony”, International Journal on Technical and Physical Problems of Engineering (IJTPE), Issue 6, Vol., 3, No. 1, pp. 1-10.
2. R.D. Christie, A. Bose, (1996) “Load Frequency Control Issues in Power System Operations after Deregulation”, IEEE Transactions Power Systems, Vol. 11, No. 3, pp. 1191-1200.
3. J. Kumar, N. G. Hoe, G. Sheble, (1997) “AGC Simulator for Price based Operation, Part I: Modeling”, IEEE Transactions Power Systems, Vol. 12, No. 2, pp. 527-532.
4. V. Donde, A. Pai, I.A. Hiskens, (2001) “Simulation and Optimization in a AGC System after Deregulation”, IEEE Transactions on Power Systems, Vol. 16, No. 3, pp. 481- 489.
5. H. Shayeghi, H.A. Shayanfar, A. Jalili, A. Ghasemi, (2010) “LFC Design using HBMO Technique in Interconnected Power System”, International Journal on Technical and Physical Problems of Engineering (IJTPE), Issue 5, Vol. 2, No. 4, pp. 41-48.
6. H. Bevrani, Y. Mitani, K. Tsuji, (2004) “Robust Decentralized AGC in a Restructured Power System”, Energy Conversion and Management, Vol. 45, Issue 15-16, pp. 2297- 2312.
7. K.Y. Lim, Y. Wang, R. Zhou, (1996) “Robust Decentralized Load Frequency Control of Multi-Area Power System”, IEE Proceeding, Generation, Transmission and Distribution, Vol. 43, No. 5, pp. 377-386.
8. C. Chang, W. Fu, (1997) “Area Load Frequency Control Using Fuzzy Gain Scheduling of PI Controllers”, Electric Power Systems Research, Vol. 42, Issue 2, pp. 145-152.
9. H. Shayeghi, H.A. Shayanfar, A. Jalili, M. Khazaraee, (2005) “Area Load Frequency Control using Fuzzy PID Type Controller in a Restructured Power System”, Proceeding of the International Conference on Artificial Intelligence, Las Vegas, Nevada, USA, pp. 344-350, 27-30 June 2005
10. E. Yesil, M. Guzelkaya, I. Eksin, (2004) “Self Tuning Fuzzy PID Type Load and Frequency Controller”, Energy Conversion and Management, Vol. 45, Issue 3, pp. 377- 390.
11. H. Shayeghi, A. Jalili, H.A. Shayanfar, (2007) “Robust Modified GA based Multi-Stage Fuzzy AGC,” Journal of Energy Conversion and Management, Vol.48, No.5, pp. 1656-1670.
12. H. Shayeghi, H.A. Shayanfar, O.P. Malik, (2007) “Robust Decentralized Neural Networks based AGC in a Deregulated Power System”, Electric Power System Research, Vol.77, No. 3, pp. 241-251.
13. K. Sebaa, M. Boudour, (2009) “Optimal Locations and Tuning of Robust Power System Stabilizer Using Genetic Algorithms”, Electric Power Systems Research, Vol.79, Issue 2, pp. 406-416.
