

Study and Comparison of Various MPPT Algorithms in Solar Power System

Anuradha¹ and Satish Kumar²

¹Electrical Engineering Department, RPIIT,
Karnal, Haryana 132001, India

²Electrical Engineering Department, RPIIT,
Karnal, Haryana 132001, India

Abstract— Several techniques for MPPT (maximum power point tracking of photovoltaic (PV) arrays) have been proposed. A vast literature survey starting from the earliest method is summarized in this paper. These techniques are taken from the literature dating back to the earliest methods. A comparative analysis of these different techniques can be taken as reference for the future work on solar power generation.

Index Terms—MPPT, PV panel, Solar Power..

I. INTRODUCTION

Maximum power point in solar or PV power generation gives the best possible efficiency of the PV-panel. MPPT driven by a particular technique track the maximum power point (MPP) of a photovoltaic (PV) array. Tracking is usually an essential part of a PV system. As such, many MPP tracking (MPPT) methods have been developed and implemented. The methods vary in complexity, sensors required, convergence speed, cost, range of effectiveness, implementation hardware, popularity, and in other respects. They range from the almost obvious (but not necessarily ineffective) to the most creative (not necessarily most effective). In fact, so many methods have been developed that it has become difficult to adequately determine which method, newly proposed or existing, is most appropriate for a given PV system. Given the large number of methods for MPPT, a survey of the methods would be very beneficial to researchers and practitioners in PV systems.

The focus on research work on this area per year has grown considerably of the last decades and remains strong. However, recent papers have generally had shorter, more cursory literature reviews that largely summarize or repeat the literature reviews of previous work. This approach tends to repeat what seems to be conventional wisdom that there are only a handful of MPPT techniques, when in fact there are many. This is due to the sheer volume of MPPT literature to review, conflicting with the need for brevity.

In this paper, the attention will be focused on experimental comparisons between some of these techniques, considering several irradiation conditions. Therefore, the aim of this work is to compare several widely adopted MPPT algorithms between them in order to understand which technique has the best performance. The evaluation of the algorithms' performance is based on the power measurement valuating the total energy produced by the panel during the same test cycle. In this work, respect to the MPPT algorithm compared by simulations, the methods that need temperature or irradiance measurements are not considered for sake of simplicity. Indeed, as described in [11], these techniques do not have very high performance and they are too expensive. In the simulations, the considered MPPT techniques have been implemented strictly following the description indicated in the references: no MPPT algorithm is preferred and no MPPT techniques have been realized with more attention respect to the others.

II. PROBLEM OVERVIEW

Fig. 1 shows the characteristic power curve for a PV array. The problem considered by MPPT techniques is to automatically find the voltage V_{MPP} or current I_{MPP} at which a PV array should operate to obtain the maximum power output P_{MPP} under a given temperature and irradiance. It is noted that under partial shading conditions, in some cases it is possible to have multiple local maxima, but overall there is still only one true MPP. Most techniques respond to changes in both irradiance and temperature, but some are specifically more useful if temperature is approximately constant. Most techniques would automatically respond to changes in the array due to aging, though some are open-loop and would require periodic fine-tuning. In our context, the array will typically be connected to a power converter that can vary the current coming from the PV array.

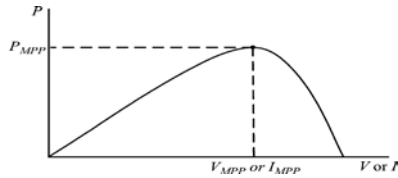

Fig. 1. Characteristic PV array power curve.

TABLE I
SUMMARY OF HILL CLIMBING AND P&O ALGORITHM

Perturbation	Change in Power	Next Perturbation
Positive	Positive	Positive
Positive	Negative	Negative
Negative	Positive	Negative
Negative	Negative	Positive

III. MPPT TECHNIQUES

We introduce the different MPPT techniques below in an arbitrary order.

A. Hill Climbing/P&O

Among all the papers we gathered, much focus has been on hill climbing [1]–[8], and perturb and observe (P&O) [9]–[25] methods. Hill climbing involves a perturbation in the duty ratio of the power converter, and P&O a perturbation in the operating voltage of the PV array. In the case of a PV array connected to a power converter, perturbing the duty ratio of power converter perturbs the PV array current and consequently perturbs the PV array voltage. Hill climbing and P&O methods are different ways to envision the same fundamental method. From Fig. 1, it can be seen that incrementing (decrementing) the voltage increases (decreases) the power when operating on the left of the MPP and decreases (increases) the power when on the right of the MPP. Therefore, if there is an increase in power, the subsequent perturbation should be kept the same to reach the MPP and if there is a decrease in power, the perturbation should be reversed. This algorithm is summarized in Table I. In [24], it is shown that the algorithm also works when instantaneous (instead of average) PV array voltage and current are used, as long as sampling occurs only once in each switching cycle. The process is repeated periodically until the MPP is reached. The system then oscillates about the MPP. The oscillation can be minimized by reducing the perturbation step size. However, a smaller perturbation size slows down the MPPT. A solution to this conflicting situation is to have a variable perturbation size that gets smaller towards the MPP as shown in [8], [12], [15], and [22]. In [24], fuzzy

logic control is used to optimize the magnitude of the next perturbation. In [20], a two-stage algorithm is proposed that offers faster tracking in the first stage.

B. Incremental Conductance

The incremental conductance (IncCond) [9], [26]–[36] method is based on the fact that the slope of the PV array power curve (Fig. 1) is zero at the MPP, positive on the left of the MPP, and negative on the right, as given by

$$\begin{aligned}
 dP/dV &= 0, \text{ at MPP} \\
 dP/dV &> 0, \text{ left of MPP} \\
 dP/dV &< 0, \text{ right of MPP.}
 \end{aligned}
 \tag{1}$$

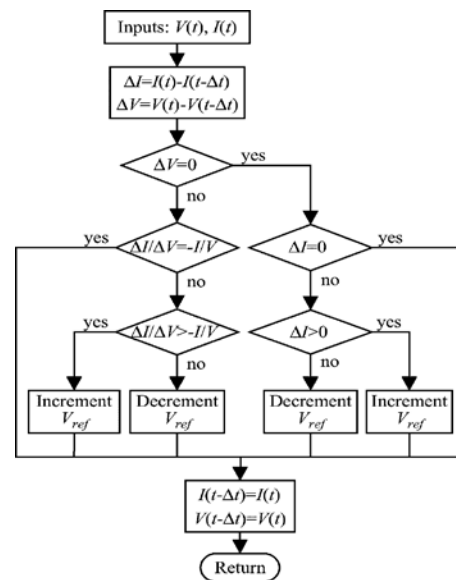

Fig. 2. IncCond algorithm chart.

The MPP can thus be tracked by comparing the instantaneous conductance (I/V) to the incremental conductance ($\Delta I/\Delta V$) as shown in the flowchart in Fig. 2. V_{ref} is the reference voltage at which the PV array is forced to operate. At the MPP, V_{ref} equals to V_{MPP} . Once the MPP is reached, the operation of the PV array is maintained at this point unless a change in ΔI is noted, indicating a change in atmospheric conditions and the MPP. The algorithm decrements or increments V_{ref} to track the new MPP. The increment size determines how fast the MPP is tracked. Fast tracking can be achieved with bigger increments but the system might not operate exactly at the MPP and oscillate about it instead; so there is a tradeoff. In [31] and [35], a method is proposed that brings the operating point of the PV array close to the MPP in a first stage and then uses IncCond to exactly track the MPP in a second stage. By proper control of the power converter, the initial operating point is set to match a load resistance proportional to the ratio of

the open-circuit voltage (V_{OC}) to the short-circuit current (I_{SC}) of the PV array. This two-stage alternative also ensures that the real MPP is tracked in case of multiple local maxima.

C. Fractional Open-Circuit Voltage

The near linear relationship between V_{MPP} and V_{OC} of the PV array, under varying irradiance and temperature levels, has given rise to the fractional V_{OC} method [30]–[35]. As $V_{MPP} \approx k_1 V_{OC}$, where k_1 is a constant of proportionality. Since k_1 is dependent on the characteristics of the PV array being used, it usually has to be computed beforehand by empirically determining V_{MPP} and V_{OC} for the specific PV array at different irradiance and temperature levels. The factor k_1 has been reported to be between 0.71 and 0.78. Once k_1 is known, V_{MPP} can be computed using V_{OC} measured periodically by momentarily shutting down the power converter. However, this incurs some disadvantages, including temporary loss of power. To prevent this, [20] uses pilot cells from which V_{OC} can be obtained. These pilot cells must be carefully chosen to closely represent the characteristics of the PV array. In [14], it is claimed that the voltage generated by pn-junction diodes is approximately 75% of V_{OC} . This eliminates the need for measuring V_{OC} and computing V_{MPP} . Once V_{MPP} has been approximated, a closed-loop control on the array power converter can be used to asymptotically reach this desired voltage. This computes only an approximation; the PV array technically never operates at the MPP. Depending on the application of the PV system, this can sometimes be adequate. Even if fractional V_{OC} is not a true MPPT technique, it is very easy and cheap to implement as it does not necessarily require DSP or microcontroller control. However, [5] points out that k_1 is no more valid in the presence of partial shading (which causes multiple local maxima) of the PV array and proposes sweeping the PV array voltage to update k_1 . This obviously adds to the implementation complexity and incurs more power loss.

D. Fractional Short-Circuit Current

Fractional I_{SC} results from the fact that, under varying atmospheric conditions, I_{MPP} is

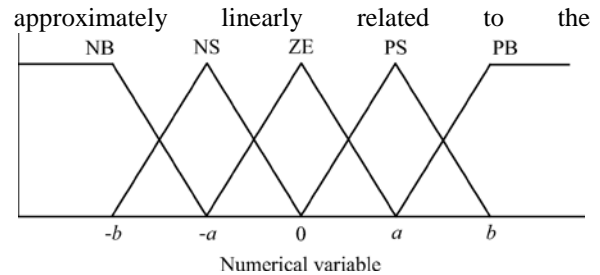

Fig. 3. Membership function for inputs and output of fuzzy logic controller.

I_{SC} of the PV array as shown in [24] $I_{MPP} \approx k_2 I_{SC}$, where k_2 is a proportionality constant. Just like in the fractional V_{OC} technique, k_2 has to be determined according to the PV array in use. The constant k_2 is generally found to be between 0.78 and 0.92.

Measuring I_{SC} during operation is problematic. An additional switch usually has to be added to the power converter to periodically short the PV array so that I_{SC} can be measured using a current sensor. This increases the number of components and cost. In [18], a boost converter is used, where the switch in the converter itself can be used to short the PV array. Power output is not only reduced when finding I_{SC} but also because the MPP is never perfectly matched as $I_{MPP} \approx k_2 I_{SC}$. In [16], a way of compensating k_2 is proposed such that the MPP is better tracked while atmospheric conditions change. To guarantee proper MPPT in the presence of multiple local maxima, [15] periodically sweeps the PV array voltage from open-circuit to short-circuit to update k_2 . Most of the PV systems using fractional I_{SC} in the literature use a DSP. In [28], a simple current feedback control loop is used instead.

E. Fuzzy Logic Control

Microcontrollers have made using fuzzy logic control [19] popular for MPPT over the last decade. As mentioned in [7], fuzzy logic controllers have the advantages of working with imprecise inputs, not needing an accurate mathematical model, and handling nonlinearity. Fuzzy logic control generally consists of three stages: fuzzification, rule base table lookup, and defuzzification. During fuzzification, numerical input variables are converted into linguistic variables based on a membership function similar to Fig. 3. In this case, five fuzzy levels are used: NB (negative big), NS (negative small), ZE (zero), PS (positive small), and PB (positive big). In [4] and [15], seven fuzzy levels are used, probably for more accuracy. In Fig. 3, a and b are based on the range of values of the numerical variable. The membership function is sometimes made less symmetric to give more importance to specific fuzzy

levels as in [9] the inputs to a MPPT fuzzy logic controller are usually an error E and a change in error ΔE . The user has the flexibility of choosing how to compute E and ΔE . Since dP/dV vanishes

TABLE II
FUZZY RULE BASE TABLE AS SHOWN IN [50]

$\Delta E \backslash E$	NB	NS	ZE	PS	PB
NB	ZE	ZE	NB	NB	NB
NS	ZE	ZE	NS	NS	NS
ZE	NS	ZE	ZE	ZE	PS
PS	PS	PS	PS	ZE	ZE
PB	PB	PB	PB	ZE	ZE

at the MPP, [8] uses the approximation

$$E(n) = P(n) - P(n - 1)$$

$$V(n) - V(n - 1) \quad (2)$$

and

$$\Delta E(n) = E(n) - E(n - 1). \quad (3)$$

Once E and ΔE are calculated and converted to the linguistic variables, the fuzzy logic controller output, which is typically a change in duty ratio ΔD of the power converter, can be looked up in a rule base table such as Table II [30]. The linguistic variables assigned to ΔD for the different combinations of E and ΔE are based on the power converter being used and also on the knowledge of the user. Table II is based on a boost converter. If, for example, the operating point is far to the left of the MPP (Fig. 1), that is E is PB, and ΔE is ZE, then we want to largely increase the duty ratio that is ΔD should be PB to reach the MPP. In the defuzzification stage, the fuzzy logic controller output is converted from a linguistic variable to a numerical variable still using a membership function as in Fig. 3. This provides an analog signal that will control the power converter to the MPP. MPPT fuzzy logic controllers have been shown to perform well under varying atmospheric conditions. However, their effectiveness depends a lot on the knowledge of the user or control engineer in choosing the right error computation and coming up with the rule base table. In [6], an adaptive fuzzy logic control is proposed that constantly tunes the membership functions and the rule base table so that optimum performance is achieved. Experimental results from [21] show fast convergence to the MPP and minimal fluctuation about it. In [27], two different membership functions are empirically used to show that the tracking performance depends on the type membership functions considered.

F. Neural Network

Along with fuzzy logic controllers came another technique of implementing MPPT—neural networks [10]–[13], which are also well adapted for microcontrollers. Neural networks commonly have three layers: input, hidden, and output layers as shown in Fig. 4. The number of nodes in each layer varies and is user-dependent. The input variables can be PV array parameters like V_{OC} and I_{SC} , atmospheric data like irradiance and temperature, or any combination of these.

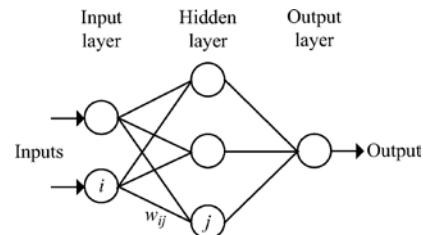

Fig. 4. Example of neural network.

How close the operating point gets to the MPP depends on the algorithms used by the hidden layer and how well the neural network has been trained. The links between the nodes are all weighted. The link between nodes i and j is labeled as having a weight of w_{ij} in Fig. 4. To accurately identify the MPP, the w_{ij} 's have to be carefully determined through a training process, whereby the PV array is tested over months or years and the patterns between the input(s) and output(s) of the neural network are recorded.

Since most PV arrays have different characteristics, a neural network has to be specifically trained for the PV array with which it will be used. The characteristics of a PV array also change with time, implying that the neural network has to be periodically trained to guarantee accurate MPPT.

G. RCC

When a PV array is connected to a power converter, the switching action of the power converter imposes voltage and current ripple on the PV array. As a consequence, the PV array power is also subject to ripple. Ripple correlation control (RCC) [28] makes use of ripple to perform MPPT

Experiments were performed to show that RCC accurately and quickly tracks the MPP, even under varying irradiance levels. The time taken to converge to the MPP is limited by the switching frequency of the power converter and the gain of the RCC circuit. Another advantage of RCC is that it does not require any prior information about the PV array characteristics, making its adaptation to different PV systems straightforward. There are other papers in the

literature that use MPPT methods that resemble RCC. For example, [6] integrates the product of the signs of the time derivatives of power and of duty ratio. However, unlike RCC, which uses inherent ripple present in current and voltage, [9] disturbs the duty ratio to generate a disturbance in power. In [66] and [7], a hysteresis-based version of RCC is used. A low frequency dithering signal is used to disturb the power in [6]. In [68], a 90° phase shift in the current (or voltage) with respect to power at the MPP is discussed, just like in RCC. The difference in [8] is that the injection is an extra, low-frequency signal and not an inherent converter ripple.

H. Current Sweep

The current sweep [9] method uses a sweep waveform for the PV array current such that the $I-V$ characteristic of the PV array is obtained and updated at fixed time intervals. The V_{MPP} can then be computed from the characteristic curve at the same intervals.

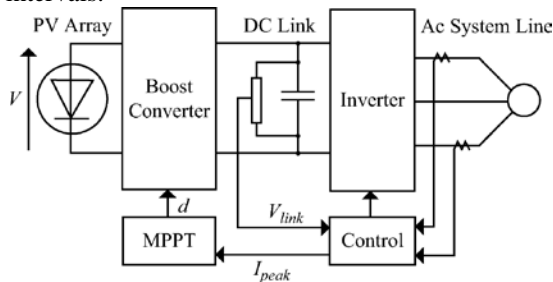

Fig. 5. Topology for dc-link capacitor droop control as shown in [71].

Once V_{MPP} is computed after the current sweep, (17) can be used to double check whether the MPP has been reached. In [9], the current sweep method is implemented through analog computation. The current sweep takes about 50 ms, implying some loss of available power. In [69], it is pointed out that this MPPT technique is only feasible if the power consumption of the tracking unit is lower than the increase in power that it can bring to the entire PV system.

I. DC-Link Capacitor Droop Control

DC-link capacitor droop control [10], [11] is an MPPT technique that is specifically designed to work with a PV system that is connected in parallel with an ac system line as shown in Fig. 6.

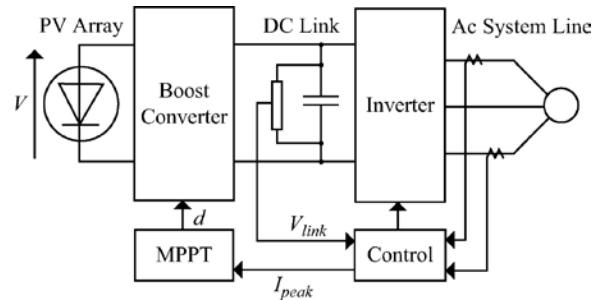

Fig. 6. Topology for dc-link capacitor droop control as shown in [71].

the current going in the inverter increases the power coming out of the boost converter and consequently increases the power coming out of the PV array. While the current is increasing, the voltage V_{link} can be kept constant as long as the power required by the inverter does not exceed the maximum power available from the PV array. If that is not the case, V_{link} starts drooping. Right before that point, the current control command I_{peak} of the inverter is at its maximum and the PV array operates at the MPP. The ac system line current is fed back to prevent V_{link} from drooping and d is optimized to bring I_{peak} to its maximum, thus achieving MPPT. DC-link capacitor droop control does not require the computation of the PV array power, but according to [12], its response deteriorates when compared to a method that detects the power directly; this is because its response directly depends on the response of the dc-voltage control loop of the inverter. This control scheme can be easily implemented with analog operational amplifiers and decision-making logic units.

J. Load Current or Load Voltage Maximization

The purpose of MPPT techniques is to maximize the power coming out of a PV array. When the PV array is connected to a power converter, maximizing the PV array power also maximizes the output power at the load of the converter. Conversely, maximizing the output power of the converter should maximize the PV array power [7]–[14], assuming a lossless converter. In [18], it is pointed out that most loads can be of voltage source type, current-source type, resistive type, or a combination of these, as shown in Fig. 7. From this figure, it is clear that for a voltage-source type load, the load current i_{out} should be maximized to reach the maximum output power P_M . For a current-source type load, the load voltage v_{out} should be maximized. For the other load types, either i_{out} or v_{out} can be used.

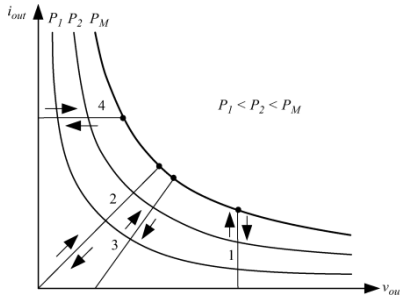

Fig. 7. Different load types. 1: voltage source, 2: resistive, 3: resistive and voltage source, 4: current source, as shown in [78].

This is also true for nonlinear load types as long as they do not exhibit negative impedance characteristics. Therefore, for almost all loads of interest, it is adequate to maximize either the load current or the load voltage to maximize the load power. Consequently, only one sensor is needed. In most PV systems, a battery is used as the main load or as a backup. Since a battery can be thought of as a voltage-source type load, the load current can be used as the control variable. In [13], [14], and [16], positive feedback is used to control the power converter such that the load current is maximized and the PV array operates close to the MPP. Operation exactly at the MPP is almost never achieved because this MPPT method is based on the assumption that the power converter is lossless.

K. dP/dV or dP/dI Feedback Control

With DSP and microcontroller being able to handle complex computations, an obvious way of performing MPPT is to compute the slope (dP/dV or dP/dI) of the PV power curve (Fig. 2) and feed it back to the power converter with some control to drive it to zero. This is exactly what is done in [9]–[5]. The way the slope is computed differs from paper to paper. In [9], dP/dV is computed and its sign is stored for the past few cycles. Based on these signs, the duty ratio of the power converter is either incremented or decremented to reach the MPP. A dynamic step size is used to improve the transient response of the system. In [80], a linearization-based method is used to compute dP/dV . In [21]–[23], sampling and data conversion are used with subsequent digital division of power and voltage to approximate dP/dV . In [22], dP/dI is then integrated together with an adaptive gain to improve the transient response. In [23], the PV-array voltage is periodically incremented or decremented and $\Delta P/\Delta V$ is compared to a marginal error until the MPP is reached. Convergence to the MPP was shown to occur in tens of milliseconds in [21].

L. Other MPPT Techniques

Other MPPT techniques include array reconfiguration [4], whereby PV arrays are arranged in different series and parallel combinations such that the resulting MPPs meet specific load requirements. This method is time consuming and tracking MPP in real time is not obvious. In [3], a linear current control is used based on the fact that a linear relationship exists between I_{MPP} and the level of irradiance. The current I_{MPP} is thus found by sensing the irradiance level and a PI controller is used such that the PV array current follows I_{MPP} . In [16], I_{MPP} and V_{MPP} are computed from equations involving temperature and irradiance levels, which are not usually easy to measure. Once I_{MPP} or V_{MPP} is obtained, feedback control is used to force the PV array to operate at the MPP. A state-based MPPT is introduced in [17], whereby the system is represented by a state space model, and a nonlinear time varying dynamic feedback controller is used to track the MPP. Simulations confirm that this technique is robust and insensitive to changes in system parameters and that MPPT is achieved even with changing atmospheric conditions and in the presence of multiple local maxima caused by partially shaded PV array or damaged cells. However, no experimental verification is given. Unlike common topologies that consist of two power stages (usually a dc–dc converter followed by an inverter), a single stage inverter that performs both MPPT and output current regulation for utility grid distribution is introduced in [8]. Based on the voltage of the PV array, one-cycle control (OCC) is used to adjust the output current of the single-stage inverter such that MPPT is attained. The control circuit consists of discrete digital components but it can also use an inexpensive DSP. Operation is shown to be close to the MPP throughout a day-time period. The slight discrepancy is due to the inability of the controller to account for temperature variation. The best fixed voltage (BFV) algorithm is introduced in [9]. Statistical data is collected about irradiance and temperature levels over a period of one year and the BFV representative of the MPP is found. The control sets either the operating point of the PV array to the BFV or the output voltage to the nominal load voltage. Operation is therefore never exactly at the MPP and different data has to be collected for different geographical regions. The PV array characteristic equation, which needs to be solved iteratively for the MPP, is manipulated to find an approximate symbolic solution for the MPP in [10]. This method, called linear reoriented coordinates method (LRCM), requires the measurement of V_{OC} and I_{SC} to find the solution. Other constants representing the PV array characteristic curve are

also needed. The maximum error in using LRCM to approximate the MPP was found to be 0.3%, but this was based only on simulation results. In [31], a slide control method with a buck-boost converter is used to achieve MPPT.

This control was implemented using a microcontroller that senses the PV array voltage and current. Simulation and experimental results showed that operation converges to the MPP in several tens of milliseconds.

IV. DISCUSSION

With so many MPPT techniques available to PV system users, it might not be obvious for the latter to

choose which one better suits their application needs. The main aspects of the MPPT techniques to be taken into consideration are highlighted in the following subsections.

A. Implementation

The ease of implementation is an important factor in deciding which MPPT technique to use. However, this greatly depends on the end-users' knowledge. Some might be more familiar with analog circuitry, in which case, fractional I_{sc} or V_{oc} , RCC, and load current or voltage maximization are good options. Others might be willing to work with digital circuitry, even if that

TABLE III
MAJOR CHARACTERISTICS OF MPPT TECHNIQUES

MPPT Technique	PV Array Dependent?	True MPPT?	Analog or Digital?	Periodic Tuning?	Convergence Speed	Implementation Complexity	Sensed Parameters
Hill-climbing/P&O	No	Yes	Both	No	Varies	Low	Voltage, Current
IncCond	No	Yes	Digital	No	Varies	Medium	Voltage, Current
Fractional V_{oc}	Yes	No	Both	Yes	Medium	Low	Voltage
Fractional I_{sc}	Yes	No	Both	Yes	Medium	Medium	Current
Fuzzy Logic Control	Yes	Yes	Digital	Yes	Fast	High	Varies
Neural Network	Yes	Yes	Digital	Yes	Fast	High	Varies
RCC	No	Yes	Analog	No	Fast	Low	Voltage, Current
Current Sweep	Yes	Yes	Digital	Yes	Slow	High	Voltage, Current
DC Link Capacitor Droop Control	No	No	Both	No	Medium	Low	Voltage
Load I or V Maximization	No	No	Analog	No	Fast	Low	Voltage, Current
dP/dV or dP/dI Feedback Control	No	Yes	Digital	No	Fast	Medium	Voltage, Current
Array Reconfiguration	Yes	No	Digital	Yes	Slow	High	Voltage, Current
Linear Current Control	Yes	No	Digital	Yes	Fast	Medium	Irradiance
I_{MPP} & V_{MPP} Computation	Yes	Yes	Digital	Yes	N/A	Medium	Irradiance, Temperature
State-based MPPT	Yes	Yes	Both	Yes	Fast	High	Voltage, Current
OCC MPPT	Yes	No	Both	Yes	Fast	Medium	Current
BFV	Yes	No	Both	Yes	N/A	Low	None
LRCM	Yes	No	Digital	No	N/A	High	Voltage, Current
Slide Control	No	Yes	Digital	No	Fast	Medium	Voltage, Current

may require the use of software and programming. Then, their selection should include hill climbing/P&O, IncCond, fuzzy logic control, neural network, and dP/dV or dP/dI feedback control. Furthermore, a few of the MPPT techniques only apply to specific topologies. For example, the dc-link capacitor droop control works with the system shown in Fig. 7 and the OCC MPPT works with a single-stage inverter.

B. Sensors

The number of sensors required to implement MPPT also affects the decision process. Most of the time, it is easier and more reliable to measure voltage than current. Moreover, current sensors are usually expensive and bulky. This might be inconvenient in systems that consist of several PV arrays with separate MPP trackers. In such cases, it might be wise to use MPPT methods that require only one sensor or that can estimate the current from the

voltage as in [25]. It is also uncommon to find sensors that measure irradiance levels, as needed in the linear current control and the I_{MPP} and V_{MPP} computation methods.

C. Multiple Local Maxima

The occurrence of multiple local maxima due to partial shading of the PV array(s) can be a real hindrance to the proper functioning of an MPP tracker. Considerable power loss can be incurred if a local maximum is tracked instead of the real MPP. As mentioned previously, the current sweep and the state based methods should track the true MPP even in the presence of multiple local maxima. However, the other methods require an additional initial stage to bypass the unwanted local maxima and bring operation to close the real MPP; such examples are given in [31] and [35].

D. Costs

It is hard to mention the monetary costs of every single MPPT technique unless it is built and implemented. This is unfortunately out of the scope of this paper. However, a good costs comparison can be made by knowing whether the technique is analog or digital, whether it requires software and programming, and the number of sensors. Analog implementation is generally cheaper than digital, which normally involves a microcontroller that needs to be programmed. Eliminating current sensors considerably drops the costs.

E. Applications

Different MPPT techniques discussed earlier will suit different applications. For example, in space satellites and orbital stations that involve large amount of money, the costs and complexity of the MPP tracker are not as important as its performance and reliability. The tracker should be able to continuously track the true MPP in minimum amount of time and should not require periodic tuning. In this case, hill climbing/P&O, IncCond, and RCC are appropriate. Solar vehicles would mostly require fast convergence to the MPP. Fuzzy logic control, neural network, and RCC are good options in this case. Since the load in solar vehicles consists mainly of batteries, load current or voltage maximization should also be considered. The goal when using PV arrays in residential areas is to minimize the payback time and to do so, it is essential to constantly and quickly track the MPP. Since partial shading (from trees and other buildings) can be an issue, the MPPT should be capable of bypassing multiple local maxima. Therefore, the two-stage IncCond [31], [35] and the current sweep methods are suitable. Since a residential system might also include an inverter, the OCC MPPT can also be used. PV systems used for street lighting only consist in charging up batteries during the day. They do not necessarily need tight constraints; easy and cheap implementation might be more important, making fractional VOC or ISC viable.

For all other applications not mentioned here, we put together Table III, containing the major characteristics of all the MPPT techniques. Table III should help in choosing an appropriate MPPT method.

V. CONCLUSION

Several MPPT techniques taken from the literature are discussed and analyzed herein, with their pros and cons. It is shown that there are several other MPPT techniques than those commonly included in literature reviews. The concluding discussion and table should serve as a useful guide in choosing the right MPPT method for specific PV systems.

REFERENCES

- [1] L. L. Buciarelli, B. L. Grossman, E. F. Lyon, and N. E. Rasmussen, "The energy balance associated with the use of aMPPT in a 100 kW peak power system," in *IEEE Photovoltaic Spec. Conf.*, 1980, pp. 523–527.
- [2] J. D. van Wyk and J. H. R. Enslin, "A study of wind power converter with microprocessor based power control utilizing an oversynchronous electronic scherbius cascade," in *Proc. IEEE Int. Power Electron. Conf.*, 1983, pp. 766–777.
- [3] W. J. A. Teulings, J. C. Marpinard, A. Capel, and D. O'Sullivan, "A new maximum power point tracking system," in *Proc. 24th Annu. IEEE Power Electron. Spec. Conf.*, 1993, pp. 833–838.
- [4] Y. Kim, H. Jo, and D. Kim, "A new peak power tracker for cost-effective photovoltaic power system," in *Proc. 31st Intersociety Energy Convers. Eng. Conf.*, 1996, pp. 1673–1678.
- [5] O. Hashimoto, T. Shimizu, and G. Kimura, "A novel high performance utility interactive photovoltaic inverter system," in *Conf. Record 2000 IEEE Ind. Applicat. Conf.*, 2000, pp. 2255–2260.
- [6] E. Koutroulis, K. Kalaitzakis, and N. C. Voulgaris, "Development of a microcontroller-based, photovoltaic maximum power point tracking control system," *IEEE Trans. Power Electron.*, vol. 16, no. 21, pp. 46–54, Jan. 2001.
- [7] M. Veerachary, T. Senjyu, and K. Uezato, "Maximum power point tracking control of IDB converter supplied PV system," in *IEE Proc. Elect. Power Applicat.*, 2001, pp. 494–502.
- [8] W. Xiao and W. G. Dunford, "A modified adaptive hill climbing MPPT method for photovoltaic power systems," in *Proc. 35th Annu. IEEE Power Electron. Spec. Conf.*, 2004, pp. 1957–1963.
- [9] O. Wasynczuk, "Dynamic behavior of a class of photovoltaic power systems," *IEEE Trans. Power App. Syst.*, vol. 102, no. 9, pp. 3031–3037, Sep. 1983.
- [10] C. Hua and J. R. Lin, "DSP-based controller application in battery storage of photovoltaic system," in *Proc. IEEE IECON 22nd Int. Conf. Ind. Electron., Contr. Instrum.*, 1996, pp. 1705–1710.
- [11] M. A. Slonim and L. M. Rahovich, "Maximum power point regulator for 4 kW solar cell array connected through inverter to the AC grid," in *Proc. 31st Intersociety Energy Convers. Eng. Conf.*, 1996, pp. 1669–1672.
- [12] A. Al-Amoudi and L. Zhang, "Optimal control of a grid-connected PV system for maximum power point tracking and unity power factor," in *Proc. Seventh Int. Conf. Power Electron. Variable Speed Drives*, 1998, pp. 80–85.
- [13] N. Kasa, T. Iida, and H. Iwamoto, "Maximum power point tracking with capacitor identifier for photovoltaic power system," in *Proc. Eighth Int. Conf. Power Electron. Variable Speed Drives*, 2000, pp. 130–135.
- [14] L. Zhang, A. Al-Amoudi, and Y. Bai, "Real-time maximum power point tracking for grid-connected photovoltaic systems," in *Proc. Eighth Int. Conf. Power Electronics Variable Speed Drives*, 2000, pp. 124–129.
- [15] C.-C. Hua and J.-R. Lin, "Fully digital control of distributed photovoltaic power systems," in *Proc. IEEE Int. Symp. Ind. Electron.*, 2001, pp. 1–6.
- [16] M.-L. Chiang, C.-C. Hua, and J.-R. Lin, "Direct power control for distributed PV power system," in *Proc. Power Convers. Conf.*, 2002, pp. 311–315.
- [17] K. Chomsuwan, P. Prisuwana, and V. Monyakul, "Photovoltaic grid connected inverter using two-switch buck-boost converter," in *Conf. Record Twenty-Ninth IEEE Photovoltaic Spec. Conf.*, 2002, pp. 1527–1530.
- [18] Y.-T. Hsiao and C.-H. Chen, "Maximum power tracking for photovoltaic power system," in *Conf. Record 37th IAS Annu. Meeting Ind. Appl. Conf.*, 2002, pp. 1035–1040.
- [19] Y. Jung, G. Yu, J. Choi, and J. Choi, "High-frequency DC link inverter for grid-connected photovoltaic system," in *Conf. Record Twenty-Ninth IEEE Photovoltaic Spec. Conf.*, 2002, pp. 1410–1413.
- [20] S. Jain and V. Agarwal, "A new algorithm for rapid tracking of approximate maximum power point in photovoltaic systems," *IEEE Power Electron. Lett.*, vol. 2, no. 1, pp. 16–19, Mar. 2004.

- [21] T. Tafticht and K. Agbossou, "Development of a MPPT method for photovoltaic systems," in *Canadian Conf. Elect. Comput. Eng.*, 2004, pp. 1123–1126.
- [22] N. Femia, G. Petrone, G. Spagnuolo, and M. Vitelli, "Optimization of perturb and observe maximum power point tracking method," *IEEE Trans. Power Electron.*, vol. 20, no. 4, pp. 963–973, Jul. 2005.
- [23] P. J. Wolfs and L. Tang, "A single cell maximum power point tracking converter without a current sensor for high performance vehicle solar arrays," in *Proc. 36th Annu. IEEE Power Electron. Spec. Conf.*, 2005, pp. 165–171.
- [24] N. S. D'Souza, L. A. C. Lopes, and X. Liu, "An intelligent maximum power point tracker using peak current control," in *Proc. 36th Annu. IEEE Power Electron. Spec. Conf.*, 2005, pp. 172–177.
- [25] N. Kasa, T. Iida, and L. Chen, "Flyback inverter controlled by sensorless current MPPT for photovoltaic power system," *IEEE Trans. Ind. Electron.*, vol. 52, no. 4, pp. 1145–1152, Aug. 2005.
- [26] A. F. Boehringer, "Self-adapting dc converter for solar spacecraft power supply," *IEEE Trans. Aerosp. Electron. Syst.*, vol. AES-4, no. 1, pp. 102–111, Jan. 1968.
- [27] E. N. Costogue and S. Lindena, "Comparison of candidate solar array maximum power utilization approaches," in *Intersociety Energy Conversion Eng. Conf.*, 1976, pp. 1449–1456.
- [28] J. Harada and G. Zhao, "Controlled power-interface between solar cells and ac sources," in *IEEE Telecommun. Power Conf.*, 1989, pp. 22.1/1–22.1/7.
- [29] K. H. Hussein and I. Mota, "Maximum photovoltaic power tracking: An algorithm for rapidly changing atmospheric conditions," in *IEE Proc. Generation Transmiss. Distrib.*, 1995, pp. 59–64.
- [30] A. Brambilla, M. Gambarara, A. Garutti, and F. Ronchi, "New approach to photovoltaic arrays maximum power point tracking," in *Proc. 30th Annu. IEEE Power Electron. Spec. Conf.*, 1999, pp. 632–637.
- [31] K. Irisawa, T. Saito, I. Takano, and Y. Sawada, "Maximum power point tracking control of photovoltaic generation system under non-uniform insolation by means of monitoring cells," in *Conf. Record Twenty-Eighth IEEE Photovoltaic Spec. Conf.*, 2000, pp. 1707–1710.
- [32] T.-Y. Kim, H.-G. Ahn, S. K. Park, and Y.-K. Lee, "A novel maximum power point tracking control for photovoltaic power system under rapidly changing solar radiation," in *IEEE Int. Symp. Ind. Electron.*, 2001, pp. 1011–1014.
- [33] Y.-C. Kuo, T.-J. Liang, and J.-F. Chen, "Novel maximum-power-point tracking controller for photovoltaic energy conversion system," *IEEE Trans. Ind. Electron.*, vol. 48, no. 3, pp. 594–601, Jun. 2001.
- [34] G. J. Yu, Y. S. Jung, J. Y. Choi, I. Choy, J. H. Song, and G. S. Kim, "A novel two-mode MPPT control algorithm based on comparative study of existing algorithms," in *Conf. Record Twenty-Ninth IEEE Photovoltaic Spec. Conf.*, 2002, pp. 1531–1534.
- [35] K. Kobayashi, I. Takano, and Y. Sawada, "A study on a two stage maximum power point tracking control of a photovoltaic system under partially shaded insolation conditions," in *IEEE Power Eng. Soc. Gen. Meet.*, 2003, pp. 2612–2617.
- [36] W. Wu, N. Pongratananukul, W. Qiu, K. Rustom, T. Kasparis, and I. Batarseh, "DSP-based multiple peak power tracking for expandable power system," in *Eighteenth Annu. IEEE Appl. Power Electron. Conf. Expo.*, 2003, pp. 525–530.