

# Intelligent Monitoring System of Ship Engine Room Based on CAN Bus

Wang Ming-qian

(School of Information Engineering, Changzhou Vocational Institute of Mechatronic Technology, Changzhou, Jiangsu Province, 213164)

**Abstract:** The monitoring system which on the base of the CAN trunk has been introduced according to the functional requirement of monitoring system for ship's engine room. We design the information node to measure and control the CAN trunk. Then, we introduce the design point of information node in measurement and control and we also make a detailed introduction and analysis on the design part of the main hardware circuit. Afterwards, we write the program of below operator system on CAN measurement and control node. We make a study on the aspect of intelligent data analysis capabilities of fuzzy neural network theory. It combines the features of fuzzy information which used by the fuzzy logic system, parallel processing which used by the artificial neural network, highly self-organization and self-study together. According to the diagnosis on the complicated system fault of marine diesel engine, we combine the modified Particle Swarm Optimization (PSO) Arithmetic with the diagnosis model on the fuzzy neural network together, and then make an optimization training on its parameter. Finally, we take advantage of Visual C++ to design a polymorphic monitoring software which on the base of data.

**Key words:** CAN trunk; monitoring system; Particle Swarm Optimization(PSO) Arithmetic; diagnosis on fault;

CLC number: TM301

Literature identification code: A

## 1 Introduction

The ship engine room automatic system is a kind of monitoring system which includes the dynamical system and auxiliary system. And the auxiliary system includes automatic control, monitoring and alarm system. The ship engine

room automatic system includes measurement and control on the main power system, power generation system and many subsystems. The ship engine room automatic system is developing into a high level period to realize the whole ship automatic monitoring system in the integration, standardization, networking, modularization, intellectualized, serialization way and so on<sup>[1]</sup>.

The start of studying and developing the national ship engine room monitoring system is in the late 1960s. The start of studying and developing computer monitoring system is in 1980s. The common feature of these monitoring system is to finishing the automatic monitoring alarm for the ship power in a redundancy way by taking advantage of the single or several computers. It is mainly distributed control. Meanwhile, the monitoring system can make remote operation on the main power facility in central control room or drive control room<sup>[2]</sup>.

Here are some advantages of the live-trunk control system which applied on the ship. The system link has been reduced greatly and it is convenient for us to control the network design and maintenance. It is beneficial to design the module of system. And the scale of the system can be large and small because it will be able to enlarge or reduce the follow-up model of system. The use of modularized design has shortened the development period of system greatly. The reliability and anti-interference of the system is high relatively.

Thus, the ship engine room monitoring system should use the live trunk which in good instantaneity, high anti-interference, low difficulty in development and maintenance, and low cost<sup>[3]</sup>. At present, the CAN trunk, LonWorks trunk and Profibus trunk are becoming more and more popular in the application of ship field. The system which combines the advanced computer control equipment with the CAN trunk together is used in the design of ship engine room monitoring system. It has some advantages of low power, high cost performance, strong function and good instantaneity and so on<sup>[4]</sup>.

Nowadays, the limitation of the national ship engine room monitoring system is on the parameter of condition monitoring and off-limit alarm. Therefore, we should apply the intelligent data processing method into the system of fault diagnosis in order to realize the fault automatic analysis and diagnosis, and then formulate and implement maintenance decision. There are three features of intelligent fault diagnosis system. First, it can simulate people's thinking process to deal with the complicated diagnosis problem of logical inference. Second, it will search and use the specified knowledge and experience to reach the goal of diagnosis according to the requirement of the diagnosis process. Third, it has the self-study, self-adjustment and self-improvement function.

This paper is to study the integrated fault diagnosis system and make a diagnosis on the fault of marine diesel engine combustion system. This paper mainly study the ship engine room intelligent monitoring system on the base of the CAN trunk and make a design on the whole plan and individual part of the system.

## 2 The Advantage of CAN Trunk

Compared with other communication trunk, the special design of CAN trunk

highlight its advantage in the aspect of real-time, anti-interference, and flexibility of data communication. It can be particularized in the following:

(1) Up to now, CAN is the only one of live trunk which with the international standards. Then, the intelligent CAN equipment which produced by various factories will abide by the standard. Thus, it has a better market share;

(2) CAN trunk can work in many ways, but other trunk can just work in one way;

(3) The highest communication rate of CAN is up to 1Mbps (the longest distance of the communication is about 40 meters), and the longest direct distance of the communication of is up to 10 kilometers (the rate is below 5kbps);

(4) CAN take advantage of the non-destructive trunk arbitration technology<sup>[5]</sup>;

(5) It can be existed 110 nodes at most on the CAN net.

(6) The structure of CAN trunk is simple and it is easy for people to buy the necessary components to guarantee the communication. The communication media of CAN trunk can be twisted pair, optical fiber or coaxial cable<sup>[6]</sup>.

According to the above advantage analysis of CAN trunk, and taking features of the special environment in ship engine room into consideration, then we can know that it is feasible to create data communication network in the monitoring system of the ship engine room.

## 3 The Whole Design Proposal of Ship Engine Room Monitoring System

### 3.1 The Function of System

The main functions which need to be realized of ship engine room intelligent

monitoring system on the base of CAN trunk are collection of data, communication, display and alarm. The equipment of the ship engine room is various, and the monitoring system need to collect and deal with all kinds of parameter. It can mainly be divided into three parts: grouping alarm, database inquiry, and fault diagnosis.

### 3.2 The Whole Design Proposal of The System

The main function of the ship engine room monitoring system is to measure, alarm, control, record and dynamic display the important data and power settings of ship sailing and some other thermal parameters. We choose the CAN trunk to create the monitoring system for the ship engine room to get the local collection and transmission and monitoring of monitoring information. The whole system is designed in the way of standardization, modularization and networking. The picture of whole proposal of the system is shown in Figure 1.

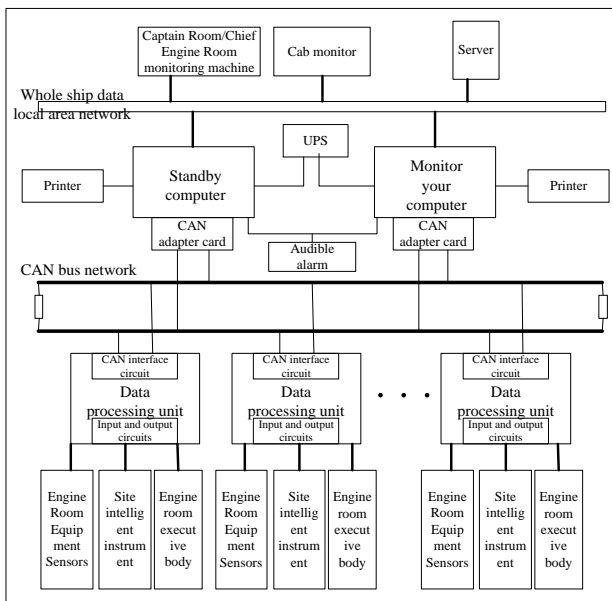

Figure 1 The structure chart of the whole system proposal

The feature of the system is that the design of modularization, the design of networking, the anti-interference and instantaneity, the friendly human-computer interface of software, and the integrated fault diagnosis module can get ride of the fault of system quickly.

## 4 The Design of Date Measurement and Control Node

### 4.1 Hardware Design of Measurement and Control Node

The data measurement and control node mainly take advantage of the design thinking of modularization, and its main task is to collect the data of sensor of the live equipment in the ship engine room. Then, it needs to display, alarm and diagnosis the fault and so on through the CAN trunk to transmit into the upper computer. Besides, it needs to accept the parameter and control command which sent by the upper computer. And all the measurement and control node will communicate with each other. The hardware structure chart is shown in the Figure 2.

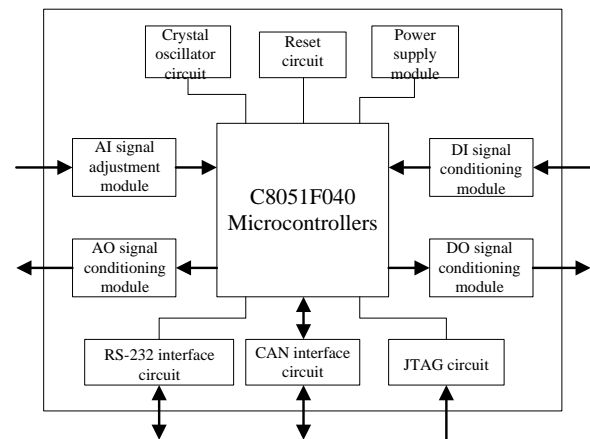

Figure 2 CAN monitoring and control node hardware structure

### 4.1.1 C8051F040 micro-controller

The micro-controller almost integrates all necessary simulated and digital peripherals and some other functional parts which need by data collection and control<sup>[7]</sup>.

### 4.1.2 CAN trunk interface circuit

The CAN controller includes the CAN nucleus, message RAM ( independent from CIP-51), state machine of message processing and control register<sup>[8]</sup>. The structure as shown in Figure 3.

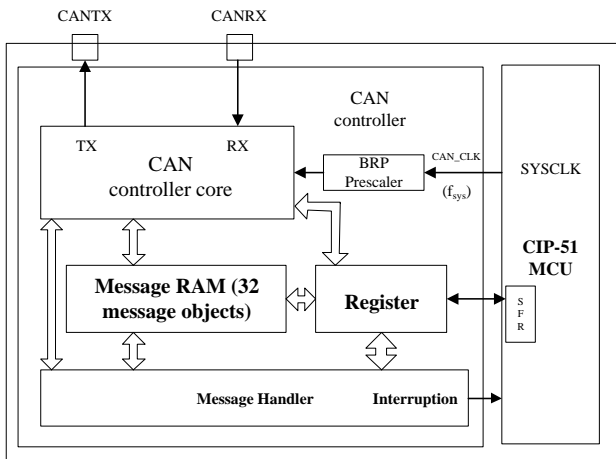

Figure 3 The structure picture of C8051F040 interior CAN controller

The C8051F040 micro-controller takes advantage of the outside CAN trunk transceiver to get the communication. The pin figure of the transceiver is shown in the Figure 4.

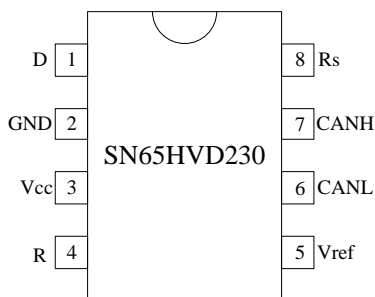

Figure 4 The pin figure of SN65HVD230

CAN trunk interface circuit in the paper is shown in Figure 5.

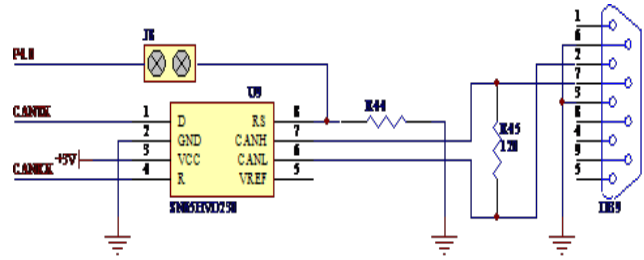

Figure 5 CAN bus interface circuit

### 4.1.3 CAN adapter

The USB2CAN adapter is shown in the Figure 6.



Figure 6 CAN adapter

## 4.2 The Design of Measurement and Control node Software

### 4.2.1 The design of main program

The flow chart of CAN measurement and control node is shown in the Figure 7.

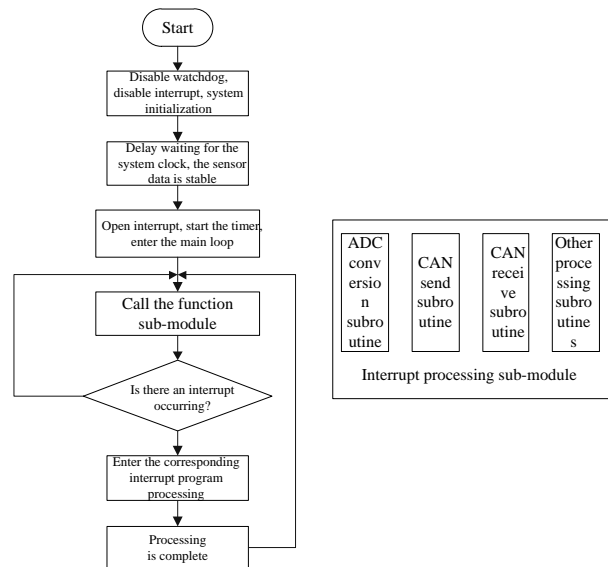

Figure 7 The flow chart of main program of CAN measurement and control node

### 4.2.2 CAN communication program design

The design of CAN communication software includes the initial program of node, the delivery of data and the reception of program. It also needs to monitor the whole condition of the trunk and diagnose or identify the network fault.

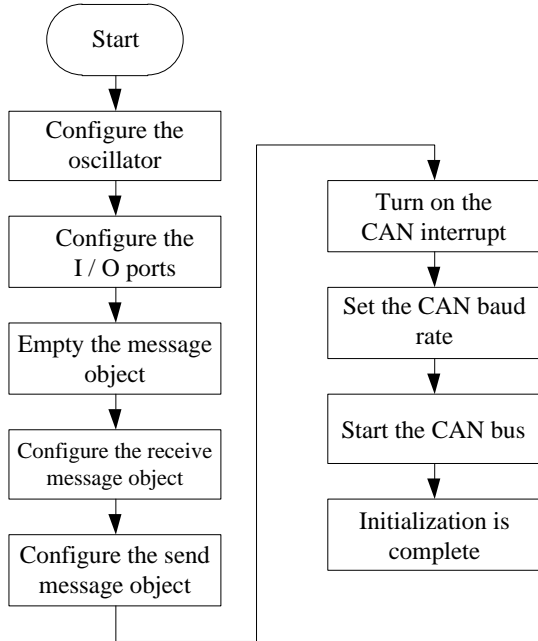

Figure 8 CAN initial flow chart

- (1) The initial setting and CAN initial flow chart is shown in Figure 8.
- (2) The subprogram flow chart is shown in Figure 9.
- (3) The flow chart of subprogram reception is shown in Figure 10.

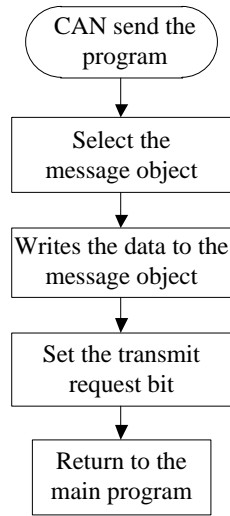

Figure 9 The flow chart of sending process of CAN subprogram

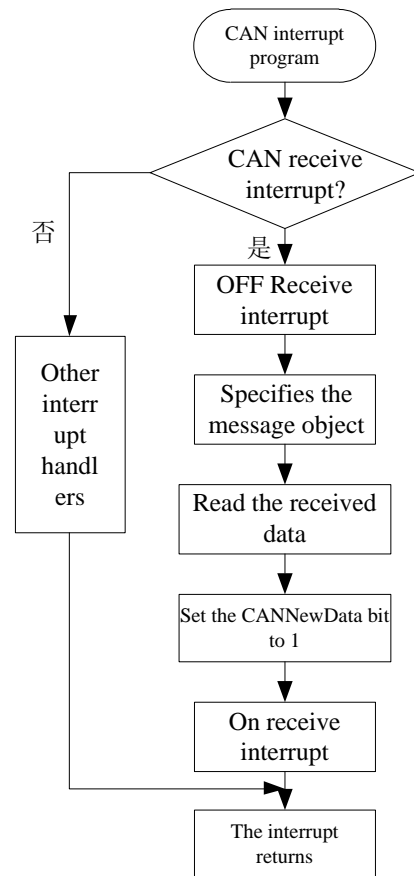

Figure 10 The flow chart of subprogram reception

## 5 The Intelligent Data Processing

### Method

#### 5.1 The Fault Diagnosis of Ship Diesel Engine

5.1.1 The nature of the fault and the diagnosis process of ship diesel engine

Generally speaking, the fault diagnosis of ship diesel engine can be separated into several steps: the study of failure mechanism; the monitoring of state; the extraction of characteristic quantity; the analysis and diagnosis of fault; the formulation and implement of maintenance decision. The whole process of the fault diagnosis of ship diesel engine is shown in the Figure 11.

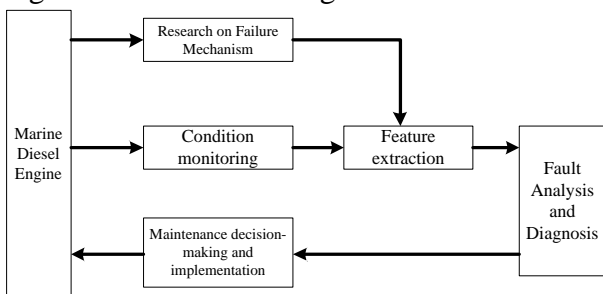

Figure 11 The fault diagnosis process of ship diesel engine

5.1.2 The parameter of fault diagnosis characteristic of ship diesel engine

We need to extract the parameter correctly, then we can form a reflection between the fault omen and state, and we can recognize the state correctly<sup>[9]</sup>. Nowadays, the methods of extracting the characteristic are mainly include state parameter, instantaneous speed, extracting the oil characteristic and so on.

#### 5.2 Fuzzy Neural Network

5.2.1 Fuzzy theory

Fuzzy theory was originally proposed by Zadeh in 1965 to provide a corresponding theoretical tool for describing and dealing with

a wide range of imprecise, ambiguous concepts and events.

5.2.2 Artificial neural networks

Artificial neural network (ANN) is a kind of artificial intelligence network system, which is developed on the basis of biological neural network and is applied to simulate the structure and function of human brain neural network. It is a large-scale, parallel processing nonlinear dynamic system<sup>[10]</sup>.

5.2.3 Typical Fuzzy Neural Network Structure

Fuzzy neural network and fuzzy neural network are combined to form a fuzzy neural network, which not only maintains the fuzzy system knowledge representation and fuzzy reasoning ability, but also has the ability of self-learning neural network, large-scale parallel computing, System function greatly enhanced<sup>[11]</sup>.

Standard fuzzy system and multi-layer feedforward network BP neural network can be combined to design a multi-input multi-output fuzzy neural network structure, as shown in Figure 12.

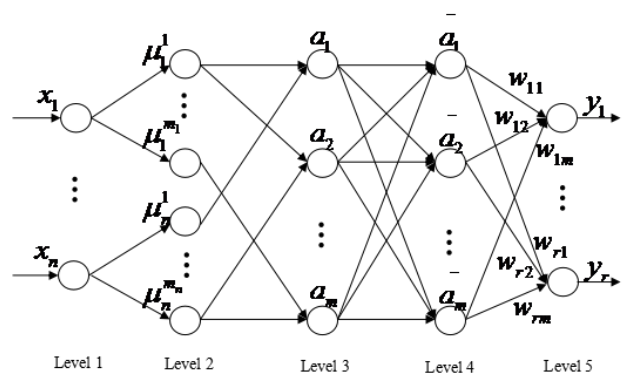

Figure 12 Standard fuzzy neural network

#### 5.3 Improved Particle Swarm Optimization Algorithm

In order to encourage the particles to traverse the entire search space at the early stage of optimization, the convergence rate of

the optimal solution is improved and the optimal solution is found in the latter stage of optimization. The standard particle swarm algorithm is improved to linearly change with the evolutionary algebra<sup>[12]</sup>:

$$c_1 = R_1 + \frac{R_2 \times t}{T_{max}} \quad (1)$$

$$c_2 = R_3 - \frac{R_4 \times t}{T_{max}} \quad (2)$$

In the formula , Adaptive control constants  $R_1$ 、 $R_2$ 、 $R_3$ 、 $R_4$  is the initial setting;  $t$  ,  $T_{max}$  are the current iteration algebra and the maximum number of iterations.

This algorithm is more focused on the convergence rate, while almost no effect on the convergence rate. To speed up the convergence rate, a linear shrinkage factor can be added to the position update formula  $k$  :

$$k = 0.5 - 0.35 * t / T_{max} \quad (3)$$

The Rosenbrock function and Schaffer F2 function are simulated by MATLAB.The best linear shrinkage factor can be obtained  $k$  :

$$x_{id}(t+1) = x_{id}(t) + kv_{id}(t+1) \quad (4)$$

The following gives a simulation example of the Rosenbrock function optimized to find its minimum value (minimum value 0).Rosenbrock function:

$$f(x, y) = 100(y - x^2)^2 + (1 - x)^2 \quad (5)$$

The main parameter of improving the particle swarm optimization includes that the number of the particle is 100, the greatest iteration is 500, the scope of particle velocity is from -1 to 1, and the scope of particle population is from -5 to 5. The  $\omega_{max}$  and  $\omega_{min}$  are 0.9 and 0.85 separately, and the control parameter  $R_1$ ,  $R_2$ ,  $R_3$ ,  $R_4$  of adaptation are 1, 0.5, 6 and 2 separately.

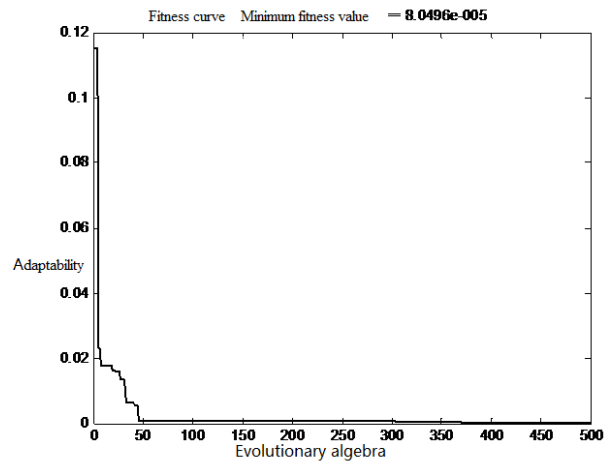

Figure 13 The simulation result which without constriction factor  $k$

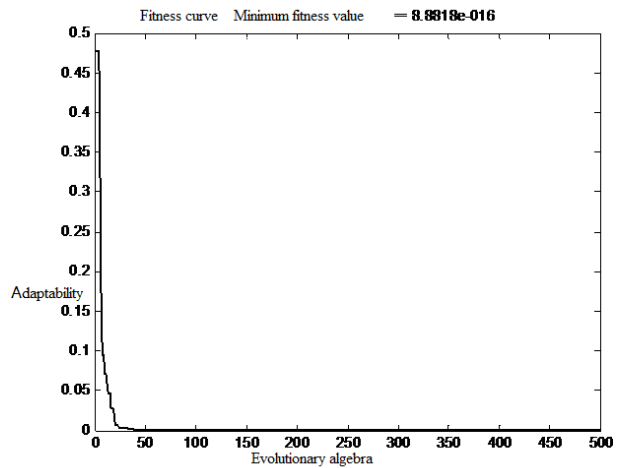

Figure 14 The simulation result which without constriction factor  $k$

Under the same experimental parameters, Figure 13 is the optimization result which without the constriction factor  $k$ , Figure 14 is the optimization result which includes the constriction factor  $k$ .

## 5.4 Fault Diagnosis of FNN Marine Diesel Engine

### 5.4.1 Fault Diagnosis Model of Marine Diesel Engine Based on

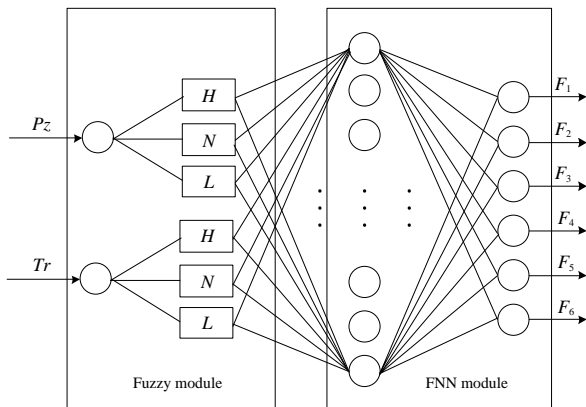

Figure 15 Fault diagnosis model of fuzzy neural network used in this paper

The fault diagnosis model of fuzzy neural network used in this paper is shown in Figure 15.

## 6 Monitoring Software Design of Host Computer.

### 6.1 Overview of Monitoring Software Functions

#### 6.1.2 Monitoring software main function

This article and the next bit of each PC Control Node CAN bus connected to a communications network, enabling PC monitor each control node, the specific function by the structure shown in Figure 16.

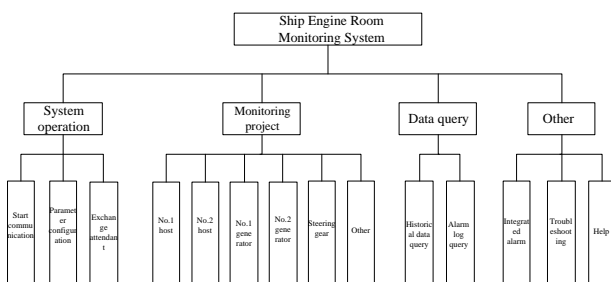

Figure 16 Structure of monitoring software function

#### 6.2 Design of PC Software

Parameter configuration module has three main functions: the host computer and the next crew of the CAN communication network

management; set the monitoring parameters of the project; set the polling interval.

The real-time monitoring module is made up of six modules.

Monitoring software, another important role is to carry out real-time data recording, storage and query.

In this paper, the host computer monitoring software design, the first through the MATCOM software has been compiled. M file compiled. Cpp source code files, and then apply it to the fault diagnosis module.

## 7 Conclusions and Future Work

We can get some conclusions from the experiment and study of the CAN ship engine room intelligent measurement and control.

(1) The ship engine room monitoring system which take advantage of the CAN trunk technology can be used to collect, control, display, alarm and diagnose the data, in order to meet the functional demands of unmanned engine room. The design of CAN node which on the base of C8051F040singlechip not only has simple structure, but also has thorough data measurement and control. And it has a strong anti-interference performance. It can deal with the fault correctly and its error detection mechanism is perfect. Among those nodes, they can communicate with each other. The upper computer monitoring software function which take advantage of Visual C++ is complete and the human-computer interface is friendly. The whole system has a strong instantaneity, high reliability and simple maintenance of communication. The flexibility and extendibility is high too. Besides, the network formulation of the whole system is simple, cheap and the cost performance is high.

(2) The intelligent degree of the system will be higher if you introduce the intelligent



optimization algorithms into the monitoring system of ship engine room. Then, we can know the condition of equipment fault of engine room instantly and diagnose the category of the fault quickly in order to provide precious time for the maintenance and the remedy of fault. And the reliability and safety of the system has also been improved greatly.

In the future, the monitoring system of ship engine room will be more intelligent, modular and networked. I hope that the study in this paper can make some contributions for the development.

## References

- [1] Liu Yue. Ship engine room automation and intelligent fault diagnosis based on.net technology research[D]. Master 's Degree Thesis of Jiangsu University of Science and Technology, 2007:3-10.
- [2] Research on engine room monitoring and control system. Mechanic Automation and Control Engineering (MACE). International Conference. Tan Ding Zhong, Qiu Ying. 2010.
- [3] Jia Chun. Application of CAN Bus in Engineering Ship Automation[J]. Ship Design Technology Exchange. 2005, (2):30-33 36-38.
- [4] Xu Hong-sheng, Lin Ye-jin. Design of Ship Monitoring System Based on Embedded System and CAN Bus[J]. 2008, 34(6):101-103.
- [5] Vdo Lutze. Reduce Control System Complexing With Fields Technology. Control Engineering[J], 1995,42(11),87-92.
- [6] Liu Yi. Design and Research of CAN Bus Protocol for Marine Diesel Engine Monitoring System[D]. Master 's Degree Thesis of Harbin Engineering University. 2010:22-24.
- [7] Song Wei. The Design of C80510F040 Single Chip Microcomputer System and Its Application in Footwear Pressure Measurement[D]. Master 's thesis of Beijing Institute of Clothing Technology. 2008:7-10.
- [8] Motorola Inc. Bosh Controller Area Network (CAN) Version2.0 PROTOCOL STANDARD Rev1.0. 1997.
- [9] Li Hong-kun. Research and Application of Marine Diesel Engine Fault Diagnosis Based on Information Fusion Technology[D]. Master 's Degree Thesis of Dalian University of Technology. 2003: 14-20.
- [10] Tao Hou-xin, Chen Li. Neural Network Control and BP Algorithm[J]. Technology and Market. 2008, (01):133-135.
- [11] Wang Zhao-xia, Chen Zeng-qiang, Yuan Zhu-zhi . Research on Network Traffic Classification Based on Fuzzy Neural Network[J]. 2004, (22):3-5.
- [12] Wei Xiu-ye, Pan Hong-xia . Particle Swarm Optimization and Intelligent Fault Diagnosis[M]. Beijing: National Defense Industry Press, 2010:35-36.